



# CHARGING STATION «CHARGE COMPLEX-T»



User manual

Ver. 2.0

©Copyright

This documentation with all illustrations is the intellectual property of PC "AE FACTORY". All documentation is provided to the user for personal use only. This documentation may not be reproduced or provided to others without our written permission. Any violation of the law will be prosecuted.



Read the user manual (Manual) carefully before using the product. All information, illustrations, tables, specifications and diagrams contained in these Manual were carefully compiled at the time of publication. Under no circumstances will compliance with the information in this Manual relieve the user of his responsibility to comply with all applicable codes, safety standards or wiring regulation. The developer cannot be held liable for any direct or indirect damages resulting from the use or operation of the electrical circuits of the equipment or software described herein.

The software is developed and installed exclusively for the operation of the station. The user is strictly prohibited from making any changes, transformations or copying the software. The developer reserves the right to make any changes in the Manual at any time without prior notice.

## CONTENT

IMPORTANT SAFETY INSTRUCTIONS .....	5
1. GENERAL INFORMATION .....	7
1.1. INTRODUCTION .....	7
1.2. CHARGING STATION TECHNICAL PARAMETERS.....	7
1.3. CONNECTORS CHARACTERISTICS .....	10
1.4. CAPACITY OF CHARGING STATIONS DEPENDING ON THE PACKAGE.....	13
2. PACKAGE.....	14
3. MARKING.....	15
4. STRUCTURE OF THE STATION .....	16
4.1. STRUCTURE OF THE CHARGING STATION .....	16
4.2. FUNCTIONAL DIAGRAM OF THE CHARGING STATION SECURITY SYSTEM.....	17
5. INSTALLATION.....	19
5.1. OPERATING LIMITATIONS .....	19
5.2. CHARGING STATION LOCATION.....	19
5.3. INSTALLATION OF THE STATION.....	20
5.4. STATION CONNECTING .....	25
5.5. INSTALLATION OF CHARGING MODULES .....	27
5.6. SETTING ADDRESSES OF CHARGING MODULES.....	30
5.7. TURNING ON THE STATION .....	31
5.8. CONNECTION OF THE STATION TO THE INTERNET NETWORK .....	31
6. EXPLOITATION .....	33
6.1. OPERATION AND CHARGING MODES OF ELECTRIC VEHICLES.....	33
6.2 START OF CHARGING .....	40
6.3. CONNECTING THE VEHICLE .....	41
6.4 END OF CHARGING.....	43
7. MAINTENANCE .....	44
7.1 SERVICE .....	44
7.2. FILTER REPLACEMENT .....	45
7.3. REPLACEMENT OF SWITCH, PROTECTIVE DISCONNECT DEVICE .....	47
7.4. REPLACEMENT OF INPUT RELAYS WITH AC/DC INVERTERS.....	47

---

7.5. INSTALLATION, REPLACEMENT, REPAIR OF CABLE TENSIONERS.....	48
7.6. REPLACEMENT OF THE DIRECT CURRENT RELAY .....	49
7.7. REPLACEMENT OF CHARGING CABLE WITH CONNECTOR.....	50
7.8. DISPLAY REPLACEMENT.....	51
7.9. INSTALLATION, REPLACEMENT OF CHARGE CONTROLLERS.....	52
7.10. MODEM REPLACEMENT (EVCC-4G).....	52
7.11. TWILIGHT SWITCH ADJUSTMENT .....	52
7.12. REPLACEMENT OF POWER MODULES.....	52
8. TROUBLESHOOTING.....	54
8.1. ERRORS DISPLAYED ON THE SCREEN OF THE STATION .....	54
8.2 EMERGENCY STOP BUTTON .....	57
8.3. TECHNICAL SUPPORT .....	57
9. STORAGE .....	57
10. TRANSPORTATION.....	58
11. DISPOSAL .....	58
12. FAT CERTIFICATE .....	58
13. MANUFACTURER'S WARRANTY .....	59

## IMPORTANT SAFETY INSTRUCTIONS

This operating manual includes the necessary sections of technical characteristics, maintenance rules, as well as safety instructions and recommendations for the operation of the station.

Before starting work, it is necessary to carefully study all the rules and recommendations given in the instructions, and observe them during operation. This will ensure reliable operation of the product and its safety in use.

Work with the charging station, observe the safety recommendations in this manual, as well as the applicable local safety regulations and general safety regulations.

Before starting any work with the charging station, make sure that the instructions, in particular the Safety section and the corresponding safety instructions, have been fully read by the personnel and fully understood.

Important safety instructions in this manual are indicated by symbols. These safety instructions must be strictly followed. You should always pay attention to them and follow the safety requirements to avoid accidents, personal injury or property damage.



### WARNING!

Risk of injury or death.

This symbol indicates instructions that must be followed to avoid injury, trauma or death.



### ATTENTION!

Risk of material damage.

This symbol indicates instructions which, if not followed, may result in material damage, functional faults and/or breakdown of the station or the vehicle connected to it.



### WARNING!

Danger - electrical current.

This symbol alerts you to potentially dangerous situations involving electric current. Failure to follow the safety instructions increases the risk of serious injury or death. Caution should be exercised, especially during maintenance and repairs.



### ATTENTION!

This symbol indicates tips and information that should be adhered to in order to ensure efficient and reliable operation of the product.

Strict adherence to the safety procedures described in these operating instructions and special care when using the equipment are essential to prevent and reduce the likelihood of injury or damage to the equipment.

The manufacturer is not responsible for any direct or indirect damages resulting from the use or work with the electrical circuits of the equipment or software described in this manual.

The manufacturer is not responsible for damage and/or malfunctions caused by noncompliance with the instructions in this manual.

The manufacturer will not be liable for any personal injury or material damage, whether indirect or special, consequential, loss of business profits, business interruption or loss of business information resulting from the use of the equipment described in this manual.

In connection with non-stop improvements, the Developer reserves the right to make changes to the construction of the equipment described in this manual without prior notice.

### **RULES FOR EXTINGUISHING THE CHARGING STATION IN FIRE:**

1. Press the emergency stop button.
2. To ensure the safety of oneself and others.
3. Call emergency services that specialize in firefighting.
4. Disconnect the power supply from the station.
5. It is possible to carry out independent fire extinguishing only when the power supply is turned off in compliance with all safety rules.

## 1. GENERAL INFORMATION

### 1.1. INTRODUCTION

**CHARGE COMPLEX-T** – is a charging station (station) designed for safe and efficient charging of electric vehicles in the specially equipped places (car parks, offices, shopping malls, etc.). It can be installed indoors or outdoors. The charging station (depending on the configuration) can simultaneously AC charging up from one to three electric vehicles.

The charging station is equipped with an intellectual control system that handles communication between the station and the electric vehicle. The control and protection functions operate continuously in the system.

The station is available in several configurations. All station configurations have one to six wires with Type 1 / Type 2 / GB / T AC / CHAdeMO / CCS Type 1 / CCS Type 2 / GB / T DC connectors and Type 2 / E-bike connectors in various combinations.

### 1.2. CHARGING STATION TECHNICAL PARAMETERS

Charging mode (IEC 61851-1)	Mode 3, mode 4
Display	LED-color touch screen 17"
Number of connectors	1...6*
Execution in a single case	+
Case material	Steel with anti-corrosion coating
Mechanical protection class (IEC 62262)	IP10
Enclosure rating (IEC 60529)	IP54
Mechanical emergency shutdown button	+
Bottom power cable entry	+
User-defined interface management	Menu functions are controlled via the app
Indication of the consumed electricity amount	+
Ability to adjust the charge current	+
Online monitoring of device operation	+
The possibility of setting a tariff	+
Operational capabilities of the Station	Autonomous work; RFID card (IEC 14443-1); Mobile app; Chip tag (optional)
Ambient temperature	-35°C...+50°C

Relative humidity	≤ 95% without moisture condensation
Weight (maximum configuration), kg	575
Dimensions (H×W×D), mm	2656×1778×507

## Output parameters:

Nominal input voltage ( $\pm 10\%$ ), V	400
The number of phases	3
Type of electrical network	TN-S
Rated supply frequency ( $\pm 0,2$ ), Hz	50/60
Maximum input current, A	255...651*
Maximum power, kW	150...406*

## Communication and protocols:

2G	GSM GPRS class 12, Quad-band: 850/900/1800/1900 МГц
3G/4G (LTE)	LTE Cat 1, LTE-FDD: B1/B3/B7/B8/B20/B28A
RFID	ISO 14443(A) (Mifare)
Ethernet	IEEE 802.3
wifi	802.11a/b/g/n
OCPP	OCPP 1.6

## Compliance with standards

EN IEC 61851-1:2019, EN 61851-23:2014, EN 61439-1:2011, EN 61439-2:2011, EN 60439-1:1999, EN 61000-6-1:2007, EN 61000-6-3:2007, IEC 61851-21-2:2018, EN 55011:2016

\* Depends on the configuration of the station.



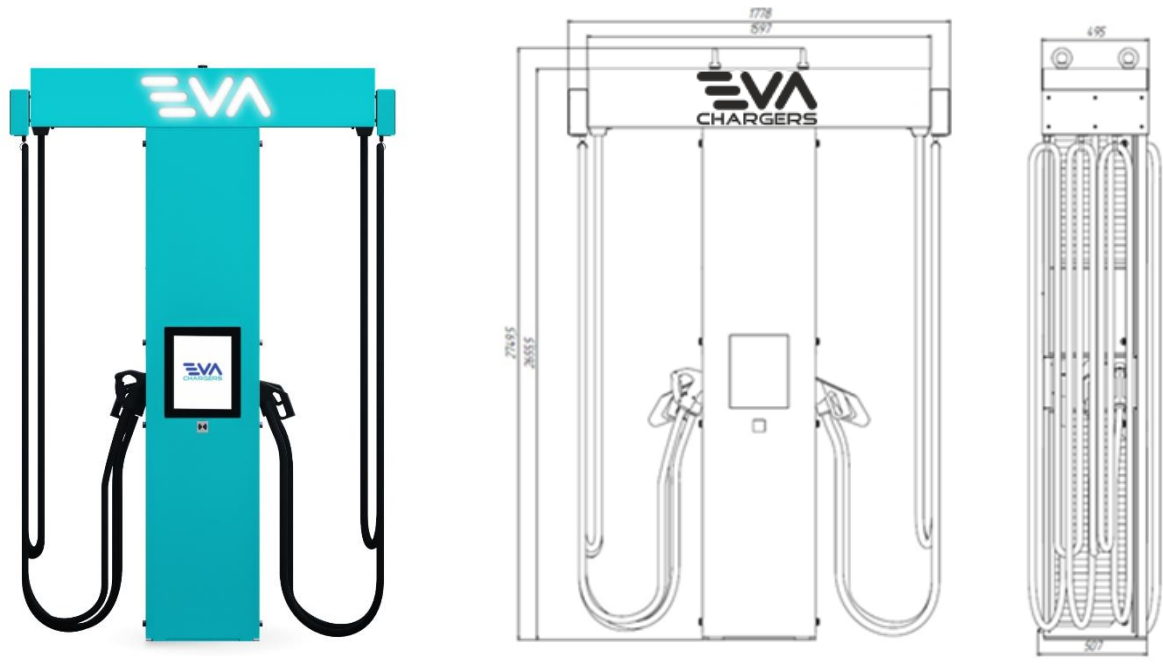


Figure 1.1. Appearance and dimensions of the station

## 1.3. CONNECTORS CHARACTERISTICS

## AC CONNECTORS

Charging station connector	Description	
Type 1		
Maximum output power	9,2 kW	18,4 kW
Maximum charging current	40 A	80 A
Maximum charging voltage	230 V	
Cable length	6.5 m	
Type 2		
Maximum output power	22 kW	43 kW
Maximum charging current	3×32 A	3×63 A
Maximum charging voltage	400 V	
Cable length	6.5 m	
GB/T AC		
Maximum output power	22 kW	43 kW
Maximum charging current	3×32 A	3×63 A
Maximum charging voltage	400 V	
Cable length	6,5 m	
Type 2 Socket		
Maximum output power	22 kW	
Maximum charging current	3×32 A	

Maximum charging voltage	400 V
--------------------------	-------

## DC CONNECTORS

Charging station connector	Description	
CHAdeMO		
Maximum output power	90 kW	
Maximum charging current	200 A	
Maximum charging voltage	500 V	
Cable length	5.5 m	
CCS Type 1		
Maximum output power	120 kW	200 kW
Maximum charging current	250 A	
Maximum charging voltage	500 V	1000 V
Cable length	5.5 m	
CCS Type 2		
Maximum output power	120 kW	240 kW
Maximum charging current	300 A	
Maximum charging voltage	500 V	1000 V
Cable length	5.5 m	
GB/T DC		
Maximum output power	120 kW	180 kW

Maximum charging current	250 A	
Maximum charging voltage	500 V	1000 V
Cable length	5.5 m	

## 1.4. CAPACITY OF CHARGING STATIONS DEPENDING ON THE PACKAGE

The charging station is produced in various configurations, the shape of which depends on the presence of connectors and the power modules used, which determine the output power of the direct current station (150-180-210-240 kW or 160-200-240-280-320).

The power value of the charging station, depending on the configuration, indicated in Table 1.2. In Table 1.2  $P_{Type2} = P_{GB/T AC}$  with similar characteristic of the connector, that is, in the case of modification, 2xType 2 (44 kW), Type 2 (22 kW) + GB/T AC (22 kW) or 2xGB/T AC with a total power of 44 kW.

Table 1.2. Power and input current of the charging station (maximum values).

$P_{DC}$ $P_{Type1}$	$P_{DC} = 150 \text{ kW}$					$P_{DC} = 160 \text{ kW}$				
	Brak Typ 1	150 (255 A)	172 (282 A)	194 (319 A)	193 (318 A)	236 (381 A)	160 (265 A)	182 (297 A)	204 (329 A)	203 (328 A)
1xTyp 1 (9,2 kW)	159.2 (295 A)	181.2 (287 A)	—	202,2 (358 A)	—	169.2 (305 A)	191.2 (337 A)	—	212,2 (368 A)	—
2xTyp 1 (18,4 kW)	168.4 (335 A)	—	—	—	—	178.4 (345 A)	—	—	—	—
1xTyp 1 (18,4 kW)	168.4 (335 A)	190.4 (367 A)	—	211,4 (398 A)	—	178.4 (345 A)	200.4 (377 A)	—	221,4 (408 A)	—
2xTyp 1 (36,8 kW)	186.8 (415 A)	—	—	—	—	196.8 (425 A)	—	—	—	—
$P_{Type1}$ $P_{Type2}$	Brak Typ 2	1xTyp 2 (22 kW)	2xTyp 2 (44 kW)	1xTyp 2 (43 kW)	2xTyp 2 (86 kW)	Brak Typ 2	1xTyp 2 (22 kW)	2xTyp 2 (44 kW)	1xTyp 2 (43 kW)	2xTyp 2 (86 kW)

$P_{DC}$ $P_{Type1}$	$P_{DC} = 180 \text{ kW}$					$P_{DC} = 200 \text{ kW}$				
	Brak Typ 1	180 (305 A)	202 (337 A)	224 (369 A)	223 (368 A)	266 (431 A)	200 (330 A)	222 (362 A)	244 (394 A)	243 (393 A)
1xTyp 1 (9,2 kW)	189,2 (345 A)	211,2 (377 A)	—	232,2 (408 A)	—	209,2 (370 A)	231,2 (402 A)	—	252,2 (433 A)	—
2xTyp 1 (18,4 kW)	198,4 (385 A)	—	—	—	—	218,4 (410 A)	—	—	—	—
1xTyp 1 (18,4 kW)	198,4 (385 A)	220,4 (417 A)	—	241,4 (448 A)	—	218,4 (410 A)	240,4 (442 A)	—	261,4 (473 A)	—
2xTyp 1 (36,8 kW)	216,8 (465 A)	—	—	—	—	236,8 (490 A)	—	—	—	—
$P_{Type1}$ $P_{Type2}$	Brak Typ 2	1xTyp 2 (22 kW)	2xTyp 2 (44 kW)	1xTyp 2 (43 kW)	2xTyp 2 (86 kW)	Brak Typ 2	1xTyp 2 (22 kW)	2xTyp 2 (44 kW)	1xTyp 2 (43 kW)	2xTyp 2 (86 kW)

Continuation of table 1.2

P <sub>DC</sub> P <sub>Type1</sub>	P <sub>DC</sub> = 210 kW					P <sub>DC</sub> = 240 kW				
	Brak Typ 1	210 (355 A)	232 (387 A)	254 (419 A)	253 (418 A)	296 (481 A)	240 (405 A)	262 (437 A)	264 (469 A)	263 (468 A)
1xTyp 1 (9,2 kW)	219,2 (395 A)	241,2 (427 A)	—	262,2 (458 A)	—	249,2 (445 A)	271,2 (477 A)	—	272,2 (508 A)	—
2xTyp 1 (18,4 kW)	228,4 (435 A)	—	—	—	—	258,4 (485 A)	—	—	—	—
1xTyp 1 (18,4 kW)	228,4 (435 A)	250,4 (467 A)	—	271,4 (498 A)	—	258,4 (485 A)	280,4 (517)	—	281,4 (548 A)	—
2xTyp 1 (36,8 kW)	246,8 (515 A)	—	—	—	—	276,8 (565 A)	—	—	—	—
P <sub>Type1</sub> P <sub>Type2</sub>	Brak Typ 2	1xTyp 2 (22 kW)	2xTyp 2 (44 kW)	1xTyp 2 (43 kW)	2xTyp 2 (86 kW)	Brak Typ 2	1xTyp 2 (22 kW)	2xTyp 2 (44 kW)	1xTyp 2 (43 kW)	2xTyp 2 (86 kW)

P <sub>DC</sub> P <sub>Type1</sub>	P <sub>DC</sub> = 280 kW					P <sub>DC</sub> = 320 kW				
	Brak Typ 1	280 (460 A)	302 (492 A)	304 (524 A)	303 (523 A)	366 (586 A)	320 (525 A)	342 (557 A)	344 (589 A)	343 (588 A)
1xTyp 1 (9,2 kW)	289,2 (500 A)	311,2 (532 A)	—	312,2 (563 A)	—	329,2 (565 A)	351,2 (597 A)	—	352,2 (628 A)	—
2xTyp 1 (18,4 kW)	298,4 (540 A)	—	—	—	—	338,4 (605 A)	—	—	—	—
1xTyp 1 (18,4 kW)	298,4 (540 A)	320,4 (572 A)	—	321,4 (603 A)	—	338,4 (605 A)	360,4 (637 A)	—	—	—
2xTyp 1 (36,8 kW)	316,8 (620 A)	—	—	—	—	—	—	—	—	—
P <sub>Type1</sub> P <sub>Type2</sub>	Brak Typ 2	1xTyp 2 (22 kW)	2xTyp 2 (44 kW)	1xTyp 2 (43 kW)	2xTyp 2 (86 kW)	Brak Typ 2	1xTyp 2 (22 kW)	2xTyp 2 (44 kW)	1xTyp 2 (43 kW)	2xTyp 2 (86 kW)

## 2. PACKAGE

Charging station "CHARGE COMPLEX-T"	1
Power module	4-8*
Metal insert**	1
Pedestal**	1
Nut M16**	4
Puck 16**	4
Grover 16**	4

\* Depends on the configuration of the station. \*\* By agreement with the customer.

### 3. MARKING

Information about the name and model of the station, basic technical parameters and serial number can be found on the plate located on the back of the station case.

Decoding the configuration.

Model: **CT BBB CCDDDE CCDDDE CCDDDE CCDDDE CCDDDE CCDDDE FFF G**

where: **CT** – «Charge Complex-T»;

**BBB** – the maximum power of the station;

**CC** – connector type;

**DDD** – the maximum current of the connector;

**E** – maximum connector voltage;

**FFF** – modem configuration;

**G** – display configuration.

Otherwise, **CCDDDE = 000000** – the connector is missing.

<b>CC:</b>	<b>E:</b>	<b>FFF:</b>	<b>G:</b>
CH – CHAdeMO;	1 – 1000 V;	2G0 – 2G-modem;	1 – LCD – display (20x2 symbols);
C1 – CCS Type 1;	2 – 230 V;	4G0 – 4G-modem;	2 – 7" – display;
C2 – CCS Type 2;	4 – 400 V;	4GE – 4G-modem with Ethernet.	3 – 17" – display.
EB – E-Bike;	5 – 500 V.		
GA – GB/T AC;			
GD – GB/T DC;			
T1 – Type 1;			
T2 – Type 2;			
S2 – Type 2 socket.			

## 4. STRUCTURE OF THE STATION

### 4.1. STRUCTURE OF THE CHARGING STATION

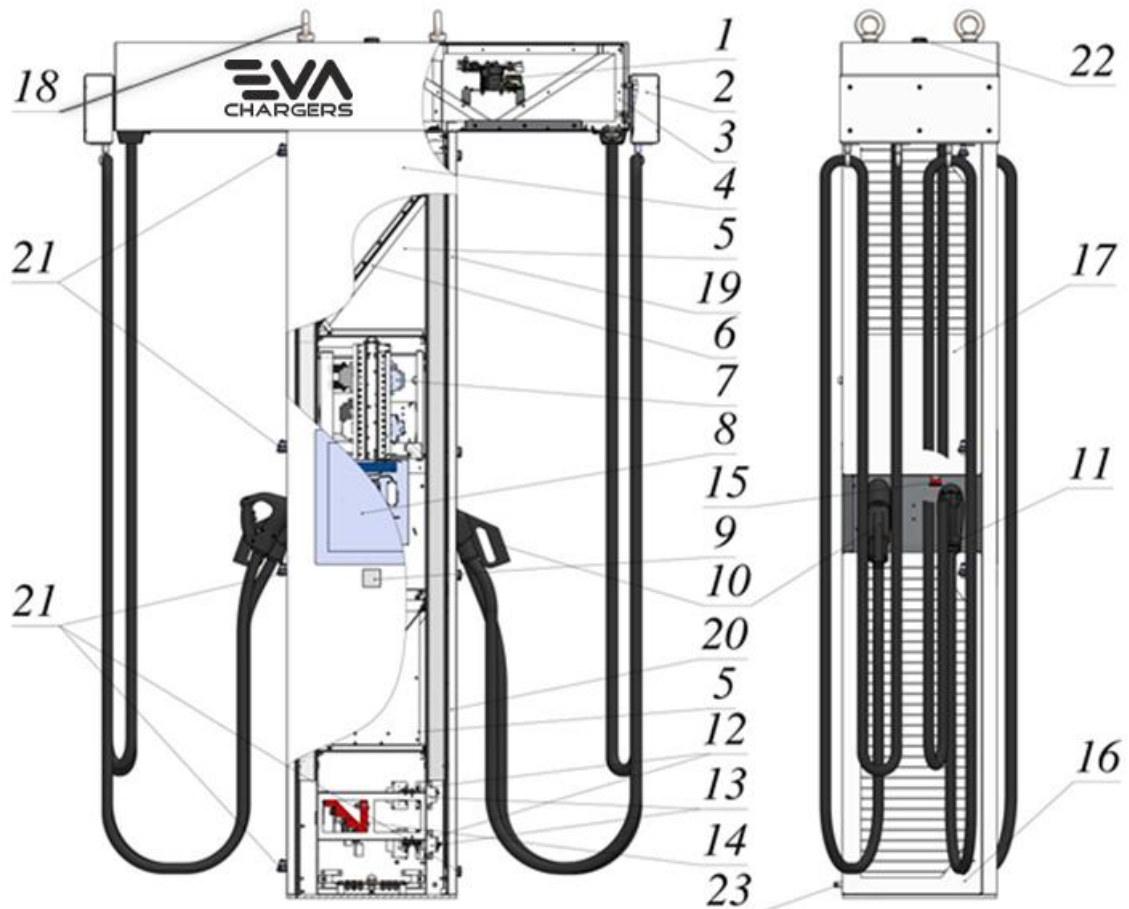


Figure 4.1. Structure of the station

- |   |                                |
|---|--------------------------------|
| 1. Contactor (relay) for inclusion sources of direct current of the car | 12. Input relays for inverters |
| 2. Cable fastening system   | 13. Input switches             |
| 3. The upper frame of the charging station                              | 14. Input terminal             |
| 4. External panels of the charging station                              | 15. Emergency stop button      |
| 5. AC/DC inverter (module).   | 16. Door 3                     |
| 6. The main frame of the charging station                               | 17. Door 4                     |
| 7. Control boards with controllers                                      | 18. Eye bolts                  |
| 8. Display  | 19. Door 2                     |
| 9. RFID-reader  | 20. Door 1                     |
| 10. Connector with CCS Type 2 cable                                     | 21. Locks                      |
| 11. Connector with CHAdeMO cable  | 22. Antenna                    |
|   | 23. External grounding sleeve  |



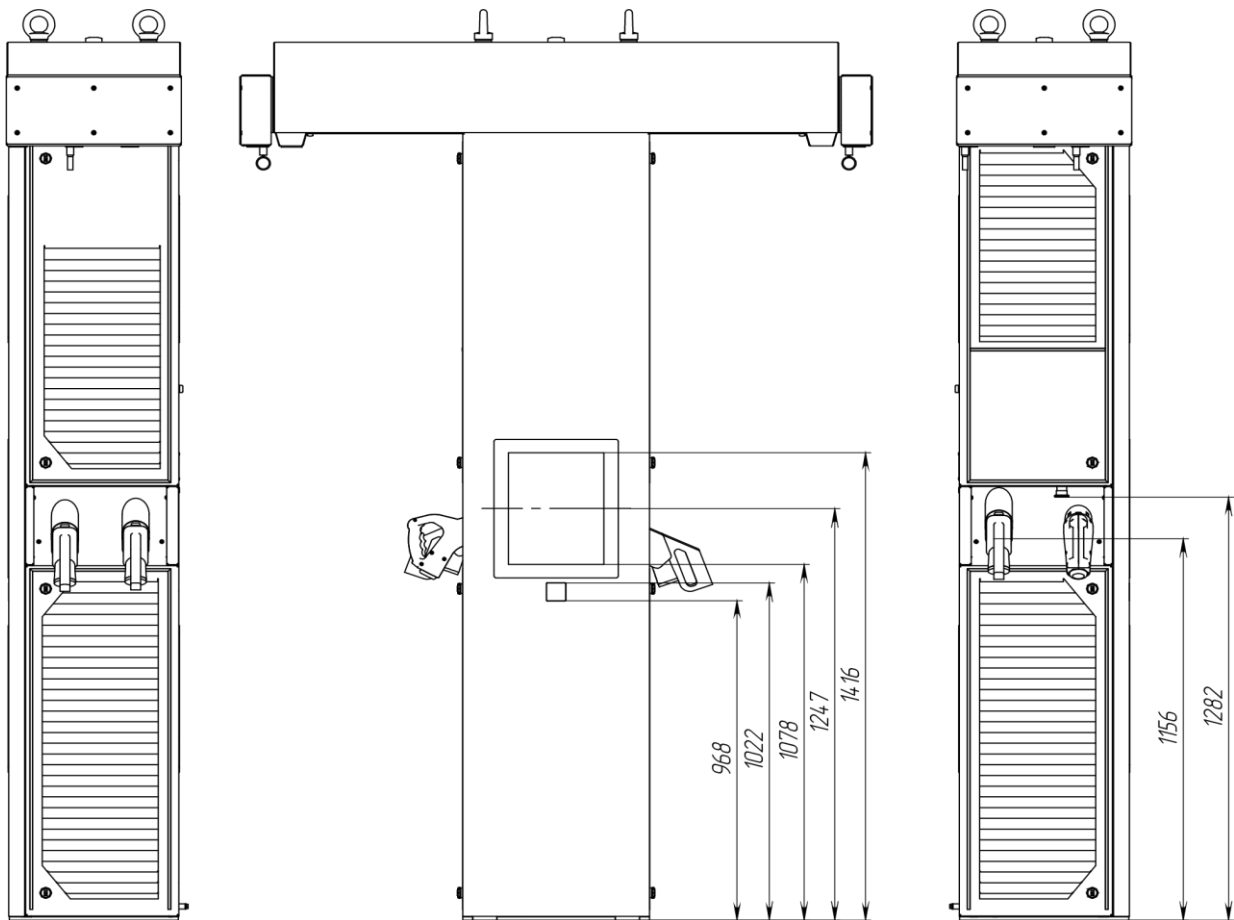


Figure 4.2. The height of the functional parts of the station.

Functional element of the station	Position height, mm
CCS Type 2 connector holder	1156
CHAdeMO connector holder	1156
RFID-reader	968-1022
Display	1078-1416
Center of the screen	1247
Emergency stop button	1282

#### 4.2. FUNCTIONAL DIAGRAM OF THE CHARGING STATION SECURITY SYSTEM

The main safety components of the station are shown on the functional diagram (Fig. 4.3).

Automatic disconnection devices are installed at the input of the charging station connection. All power circuits are protected against impulse interference.

Automatic disconnection devices are installed at the input of the charging station connection. All power circuits are protected against impulse interference.

Output circuits of charging connectors are equipped with insulation monitoring devices according to EN-61851-23.

To ensure safety standards, "EVA CHARGERS" controllers constantly monitor the voltage at the vehicle's DC connector. All DC connectors on the charging station that are not connected to the vehicle are de-energized. The voltage on the connector appears only after connecting to the car, blocking the connector in the car.

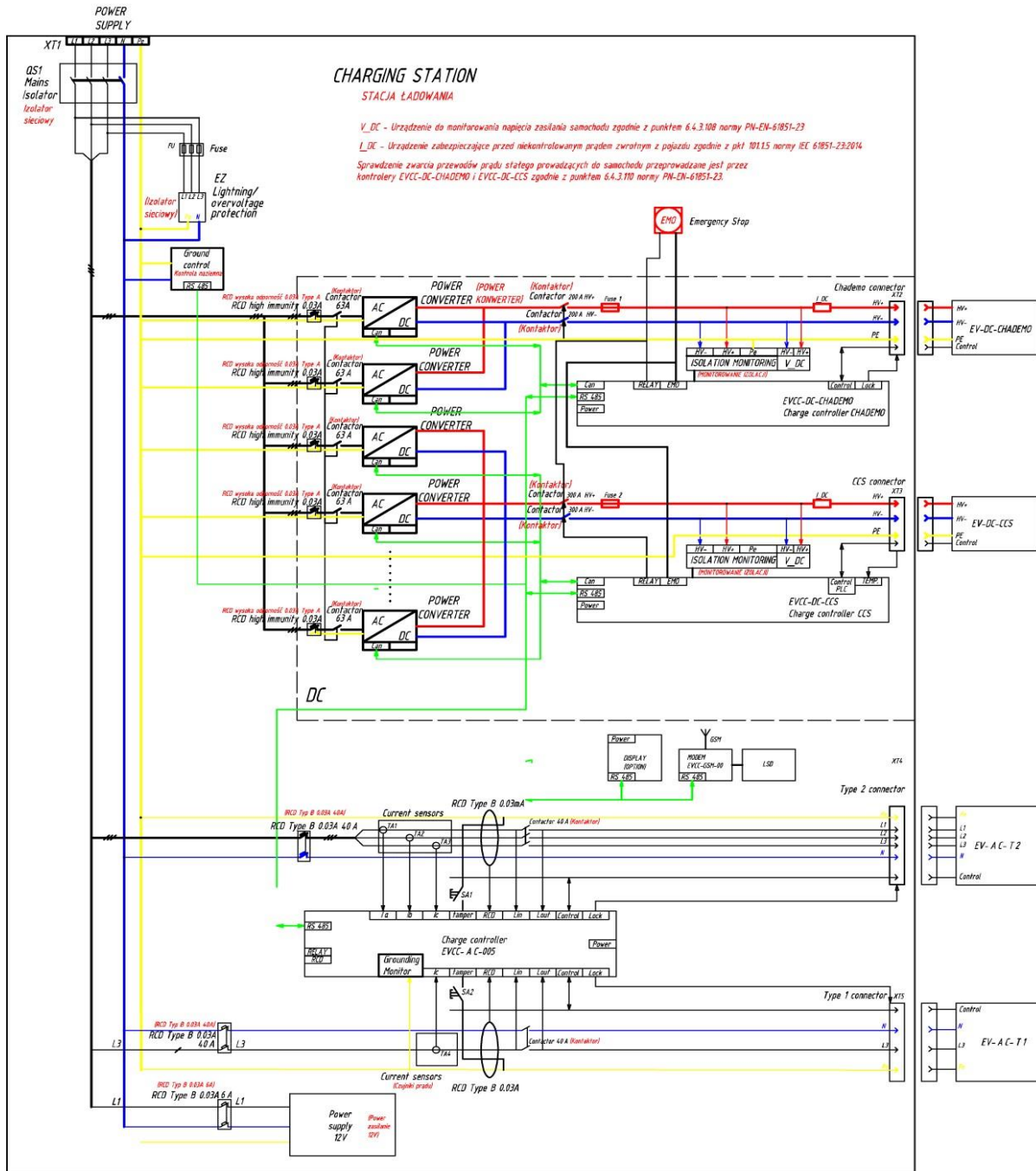


Figure 4.3. Functional security scheme

The charge controller checks the DC output circuits for short circuits before charging.

The station provides protection against uncontrolled reverse current flowing from the vehicle.

The safety control system works automatically when the charging station is turned on and before each charging of the electric vehicle. If there is an error, the error Ground Failure appears on the station's screen - failure of the ground circuit.

In case of unforeseen emergency situations (fire, explosion, electric shock), the charging station is equipped with an emergency stop button "EMO".

## 5. INSTALLATION

### 5.1. OPERATING LIMITATIONS



**The charging station is designed only for charging electric vehicles.**

**Charging only compatible electric vehicles.**

Failure to comply with the requirements for operation, maintenance and repair, described in this manual, excludes any liability of the manufacturer in the event of malfunctions in the operation of the station.

The installation altitude of the charging station above sea level should not exceed 2000 m.

Follow the safety regulations to avoid injury and material damage when working with the station.

Before the station installation, you should review this manual carefully and consult with a licensed electrician, contractor, and trained installation expert to insure compliance with local building codes, safety standards and wiring regulations.

### 5.2. CHARGING STATION LOCATION

The manufacturer recommends the location of the charging station in parking lots for 3, 4 or 6 parking spaces, depending on the number of connectors and the configuration of the parking lot.

Examples of location are shown in Fig. 5.1-5.2.

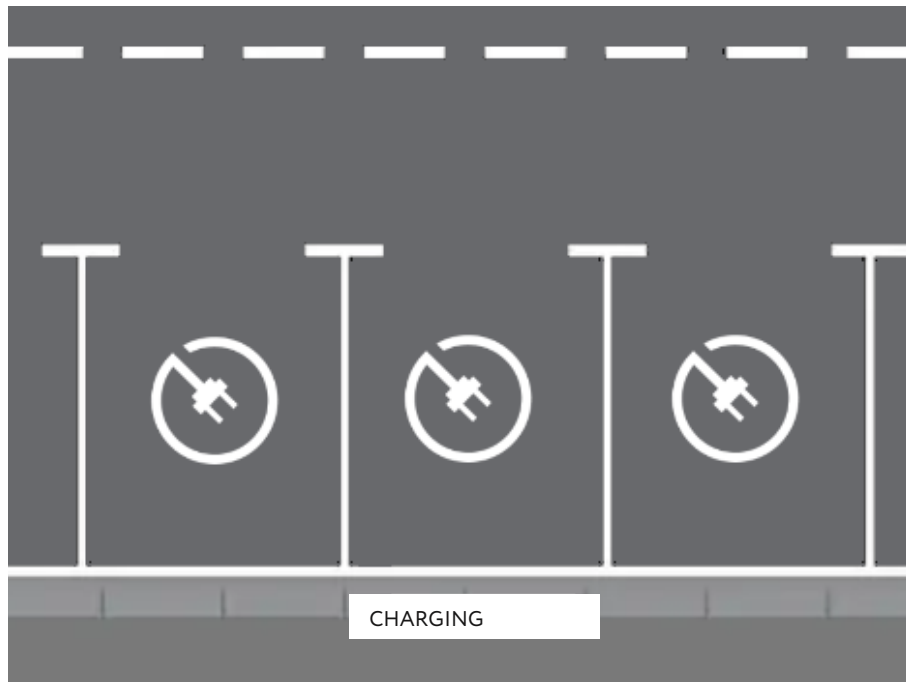


Figure 5.1. Location of the station for 3 parking spaces

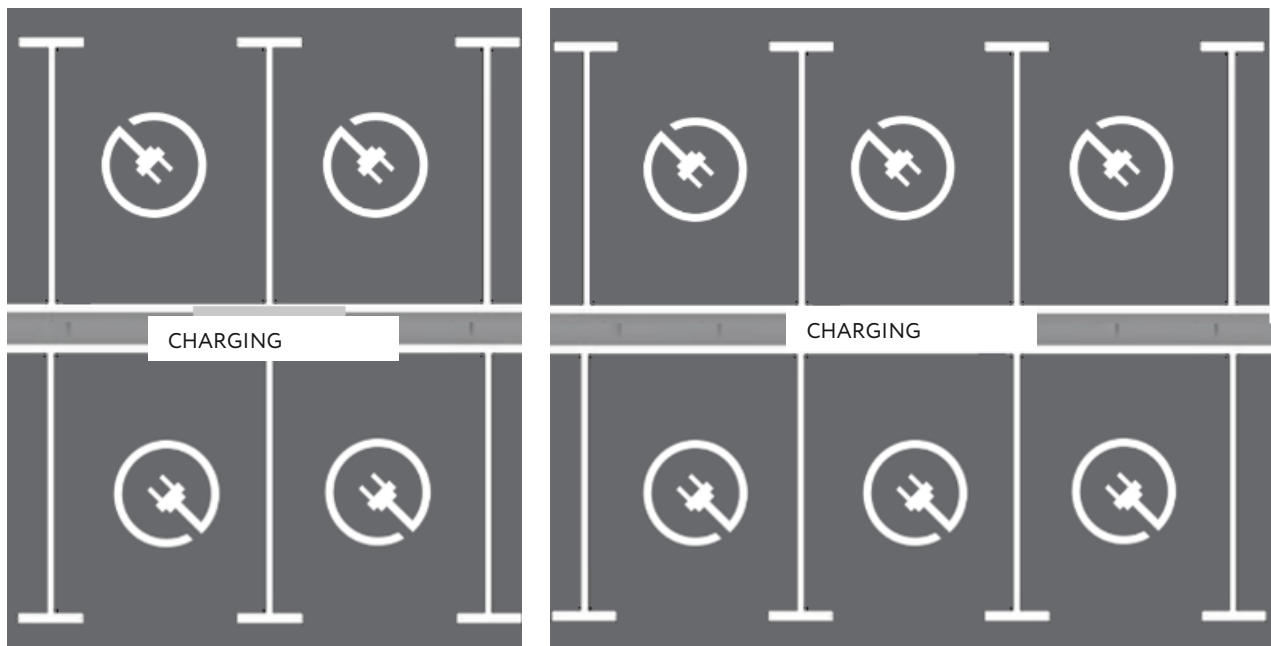


Figure 5.2. The location of the station has 4 and 6 parking spaces, respectively

### 5.3. INSTALLATION OF THE STATION

Ensure that there is sufficient GSM or 4G (LTE) cellular coverage at the installation location. Underground garages or other enclosed parking lots may require cellular signal boosters to ensure good signal strength or to connect to a local network or Wi-Fi.

The strength of the cellular signal is checked by a special device at the place of installation of the charging station.

#### Signal quality and predicted data transfer speed in 3G UMTS/WCDMA networks

RSSI (signal power)	Ec/Lo (signal/noise ratio)	Mobile Internet quality and approximate speed
from -30 to -50	from 0 to -4	Excellent performance, speed 20-40 Mbit/s
-50∞C -70∞C	from -5 to -7	Good performance, speed 15-20 Mbit/s
-70∞C -85∞C	from -7 to -10	Satisfactory work, speed 5-15 Mbit/s
-85∞C -110∞C	from -10 and less	Poor performance, below 5 Mbit/s

#### Signal quality and estimated data transfer speed in 4G LTE networks

RSSI (signal power)	SINR (signal/noise ratio)	Mobile Internet quality and approximate speed
from -30 to -50	from 30 and above	Excellent performance, speed 70-100 Mbit/s
-50∞C -70∞C	from 20 to 30	Good performance, speed 30-70 Mbit/s
-70∞C -85∞C	from 10 to 20	Satisfactory work, speed 10-30 Mbit/s
-85∞C -110∞C	from 10 and less	Poor performance, below Mbit/s

It is recommended to place the station under a canopy to protect it from direct exposure to precipitation and sunlight.

When choosing the location of the charging complex, it should be taken into account that there should be enough free space for maintenance (at least 1 meter) between the station housing and any barrier (wall).

The station is installed on a foundation (prepared concrete base) measuring 1300×1300×500 mm. Lay the cable channel. For which use a corrugated pipe  $\varnothing$  63 mm.

Schemes and descriptions of the concrete base and its reinforcement are shown in Figures 5.3-5.6.

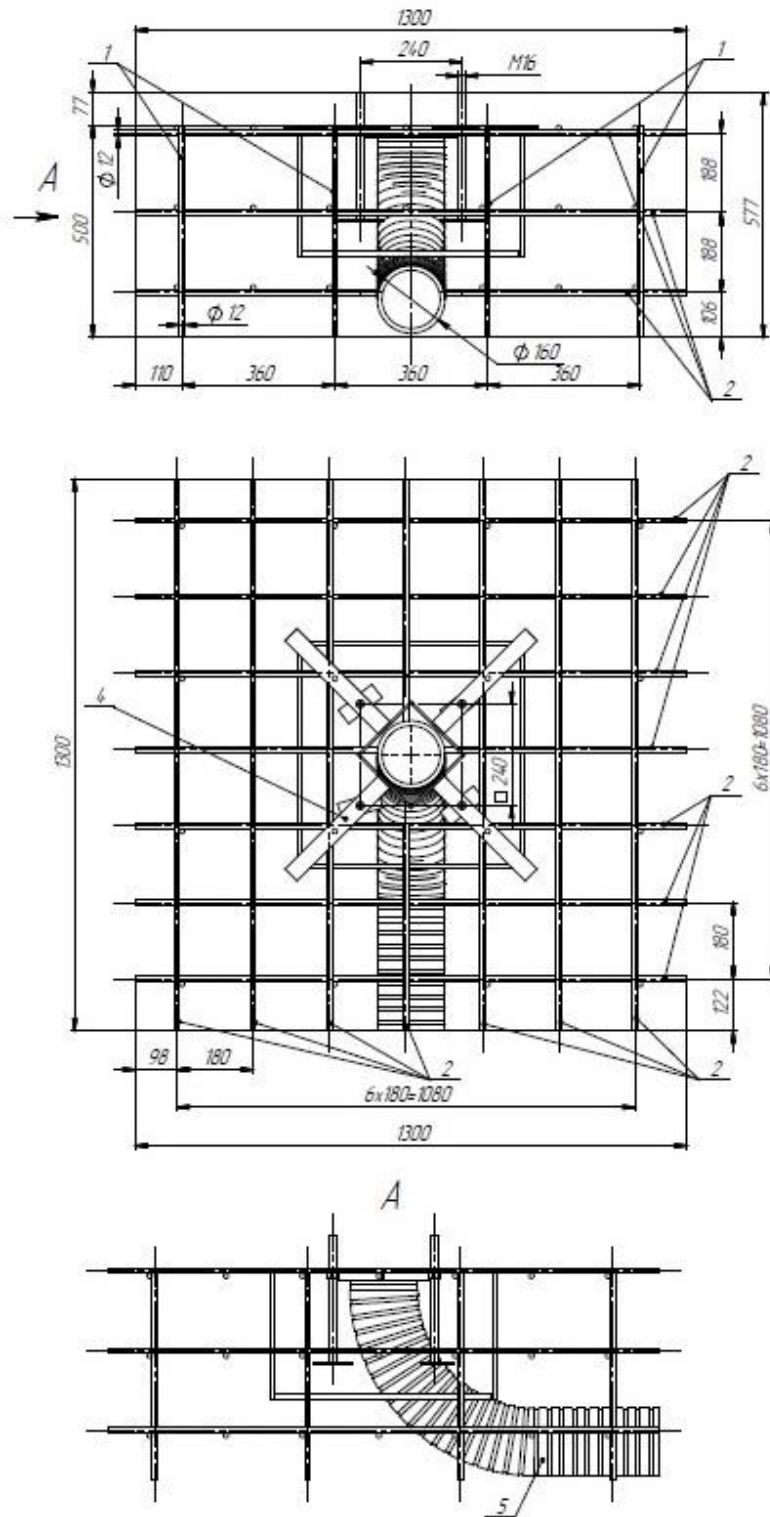


Рисунок 5.3 Схема з розмірами армування та складових бетонної основи

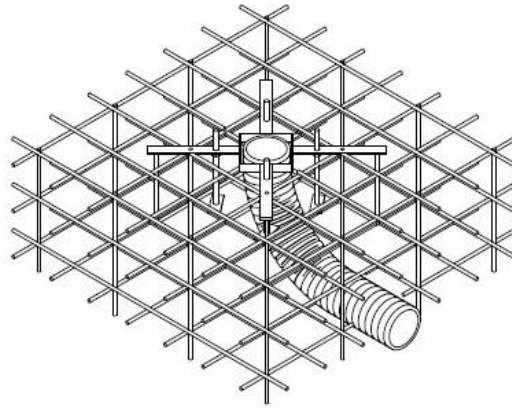


Figure 5.4. Three-dimensional scheme of concrete foundation reinforcement

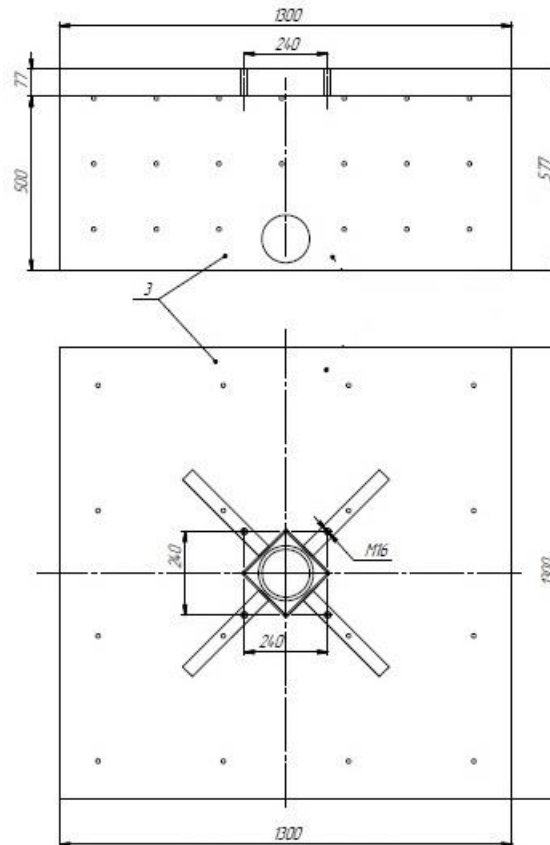


Figure 5.5. Scheme with the dimensions of the concrete base

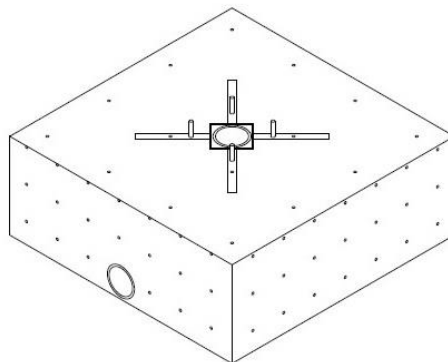


Figure 5.6. Three-dimensional scheme of the concrete foundation

For the manufacture of the foundation, it is necessary to use a mixture of crushed stone and cement not lower than M400. The surface of the foundation must be carefully leveled to prevent the station from skewing during installation.

The dimensions of the stand of the charging station are shown in Fig. 5.7, the thickness of the plate is 8 mm. When preparing the foundation, you should take care of laying the power cable (not included). The required cable length above the foundation is at least 0.6 meters.

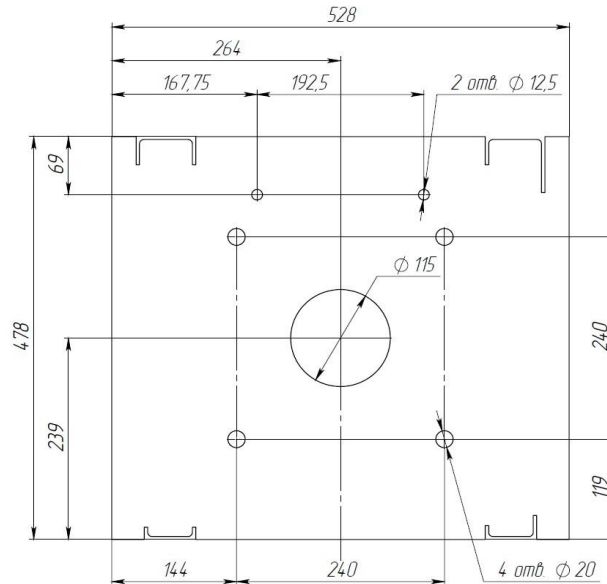


Figure 5.7. Base of the station (bottom view)

It is recommended to connect the cable based on the power of the station and operating conditions (in accordance with IEC 60502-1).



### WARNING!

**Only qualified personnel should connect the power cable to the AC mains.**

Table 5.1. Recommended cross-section of the power cable

Input current of the station, A	Cross-section of the power cable, mm <sup>2</sup>
250-300	5×120
300-360	5×150
360-420	2x(5x70)
420-480	2x(5x95)
480-550	2x(5×120)
550-680	2x(5×150)

Before connecting the complex to the power supply, it is recommended to install an AC circuit breaker between the complex and the power supply network. It is necessary for the



further maintenance of the complex. Depending on the power of the station, it is recommended to use a 3-pole circuit breaker in the range from 160 A to 630 A.

Nuts (supplied) must be turned clockwise, tightening torque - 100-130 N·m.

#### 5.4. STATION CONNECTING

After transporting the charging station, before installation, make sure that all internal elements are properly fixed and there are no mechanical damages.

Check the quality of wire, loop, and connector connections. Check the tightening torque of terminals, bolts, screws, and switchgear.

The station does not require special settings and adjustments before switching on.

Before you connect the charger, make sure that:

- The mains power cable is de-energized by external tripping devices.
- The mains input has a TN-S connection scheme: 3 phases with separate neutral (N) and grounding (PE) conductors. Network type – TN-S.
- In the case of a 4-wire connection, perform protective grounding with a separate conductor.

To connect the station to the electrical network, open door 1 (Fig. 5.8 - door 1) and pass the power cable through the cable channel.

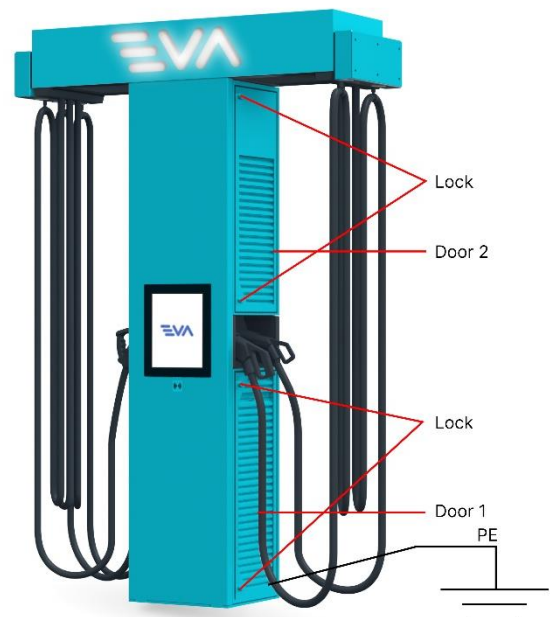


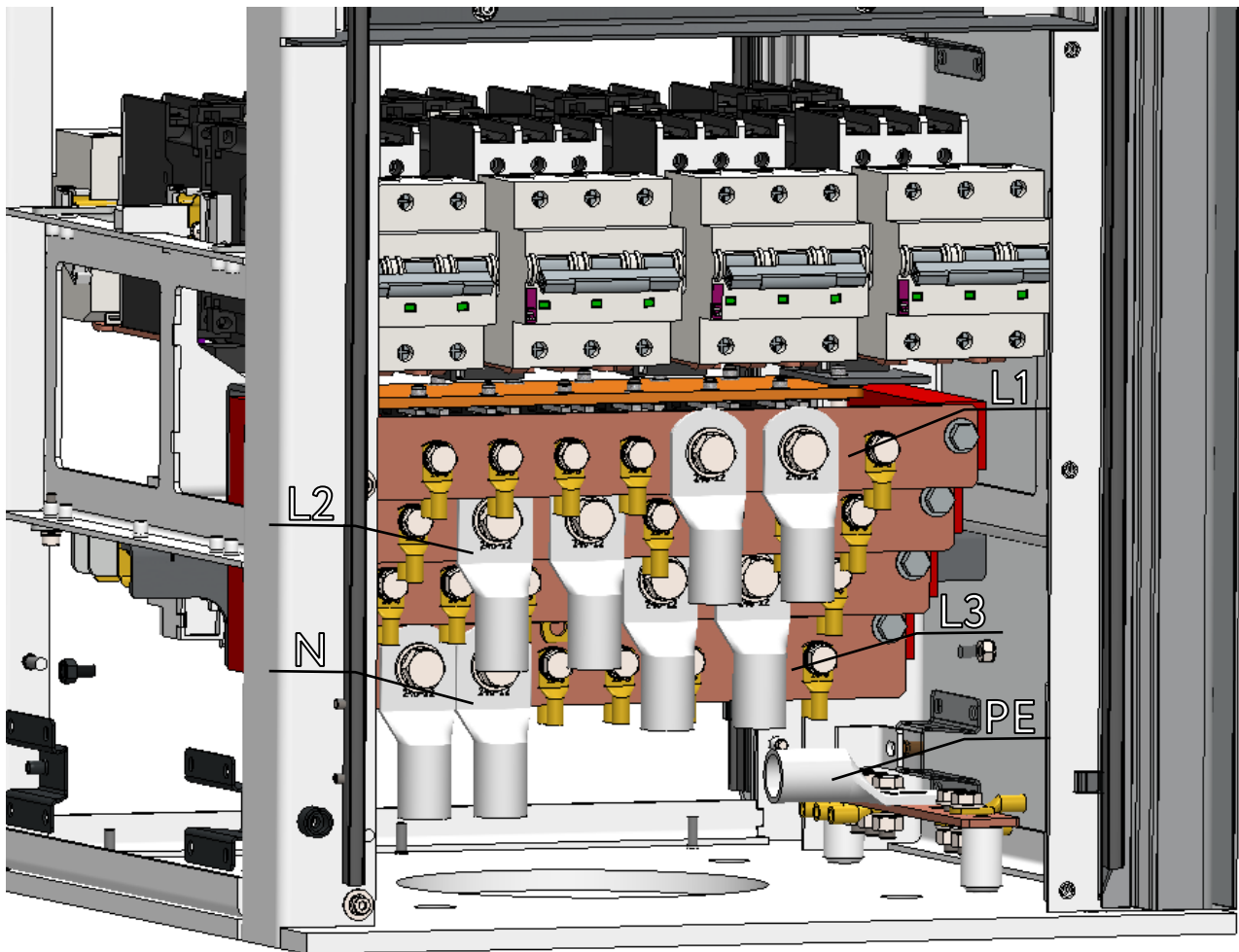
Figure 5.8. Location of doors and locks

#### GROUNDING REQUIREMENT!



The resistance of the charging station's ground loop should not exceed 4 Ω. No additional devices are allowed to be connected to the charging station's ground loop.

Next connect the power cable to the corresponding transfer busbars (as shown in Figure 5). In case of connection with a 4-wire cable, external grounding should be carried out with a wire with a cross-section of at least 25mm<sup>2</sup>, using an M10 bolted connection with the inscription "PE" located in the terminal compartment.

**ATTENTION!**

THE FIRST CONNECTION THAT SHOULD BE PERFORMED IS THE GROUND WIRE TO THE GROUND BUS LABELED "PE".

IT IS FORBIDDEN TO TURN ON THE CHARGING STATION WITHOUT A CONNECTED GROUNDING!

Figure 5.9. Input buses

## 5.5. INSTALLATION OF CHARGING MODULES

1. Unpack the power module (fig. 5.10).

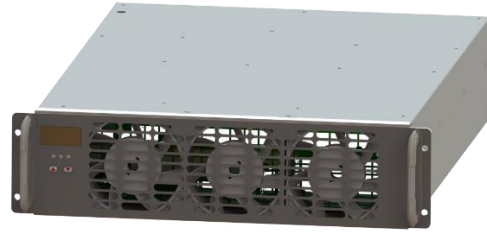


Figure 5.10. Appearance of the charging module

2. Remove screw 1 and screw 2 using a screwdriver. Remove the handle (if exist) (fig. 5.11). Remove the screws on the other side in the same way and remove the other handle (if exist).

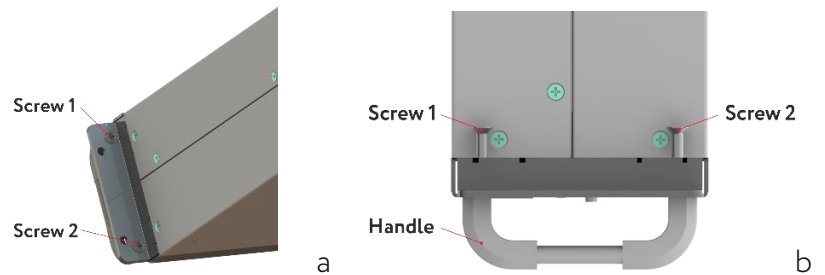


Figure 5.11. Location of fasteners and handles

4. Open the Door 1 (use Locks) (fig. 5.12).

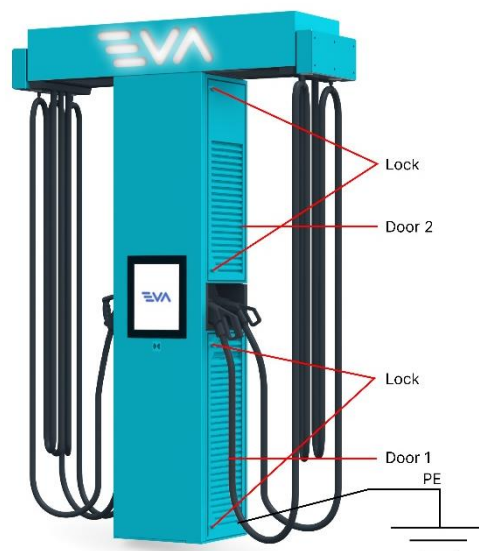


Figure 5.12. Location of doors and locks in the station

5. To install the modules on the lower level (Door 1), remove fasteners 1, 2, 3, 4 (fig. 5.13).

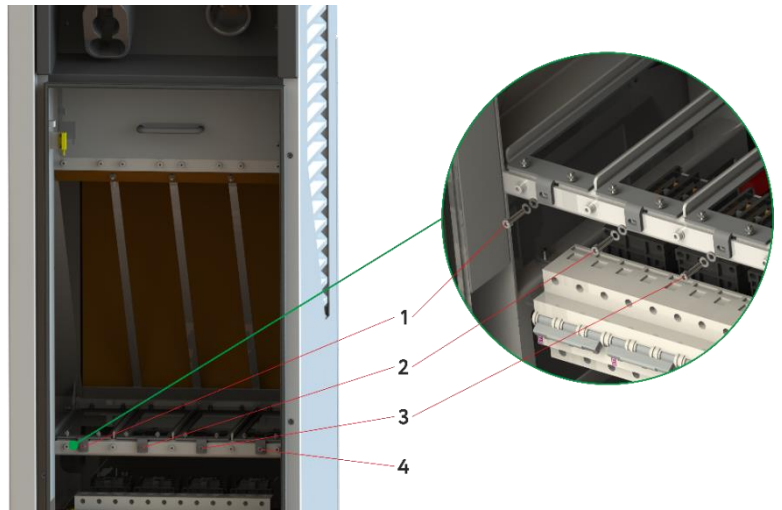


Figure 5.13. Installation location of modules

6. Take out the module bracket, remove the installed fasteners (fig. 5.14).

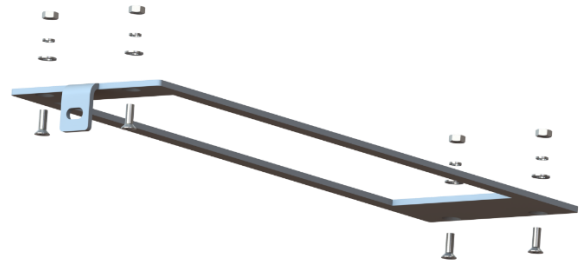


Figure 5.14. Module bracket

7. Fasten the bracket to the module with the previously removed fasteners (fig. 5.15).

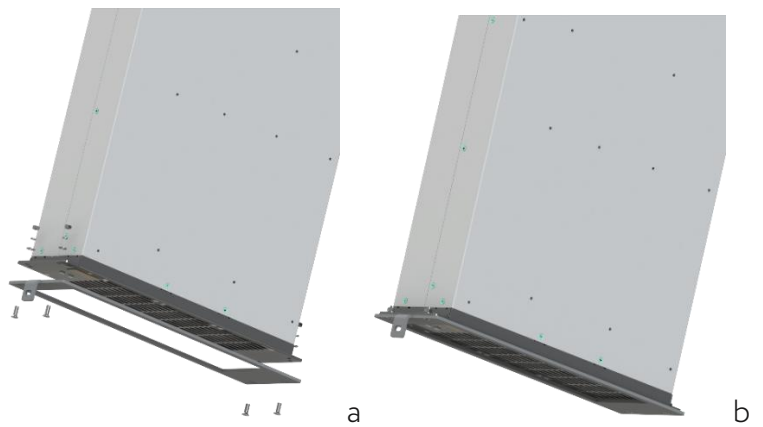


Figure 5.15. Charging module with bracket

8. Remove the fasteners 5, 6, 7 and remove the protective Panel 1 (fig. 5.16).

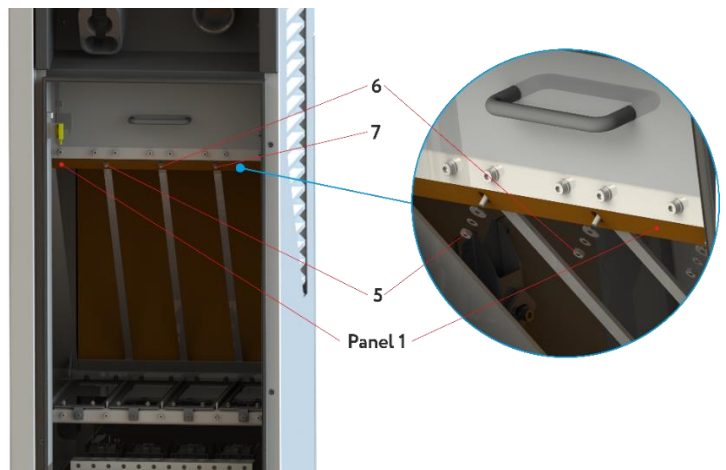


Figure 5.16. Installation location of charging modules

9. Remove the fasteners 8-11 and remove the protective Panel 2 (fig. 5.17).

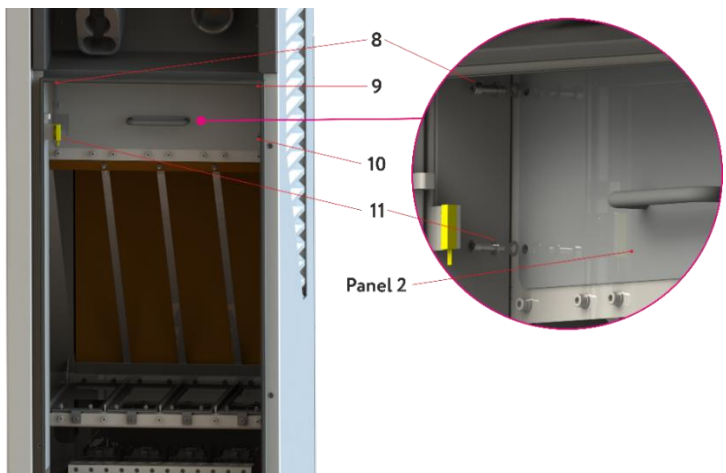


Figure 5.17. Access to the module connection compartment

10. Remove the fasteners at locations A, B, C, D. Install the module in the cell according to the marking and connect terminals 1 and 2 to the module (fig. 5.18).

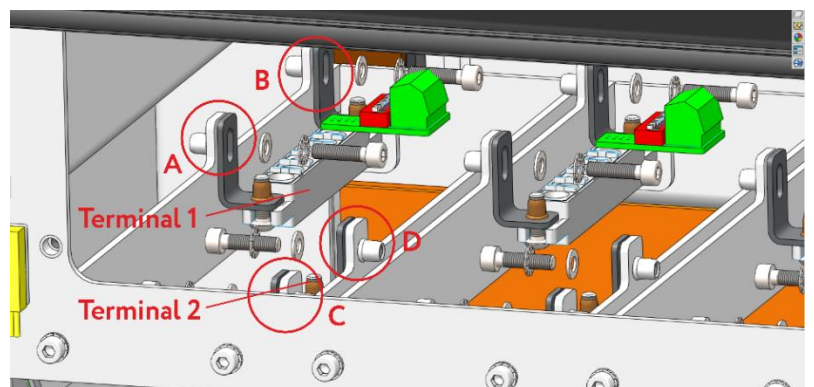


Figure 5.18. Connecting modules

11. Fasten the terminals with the previously removed fasteners (fig. 5.19).

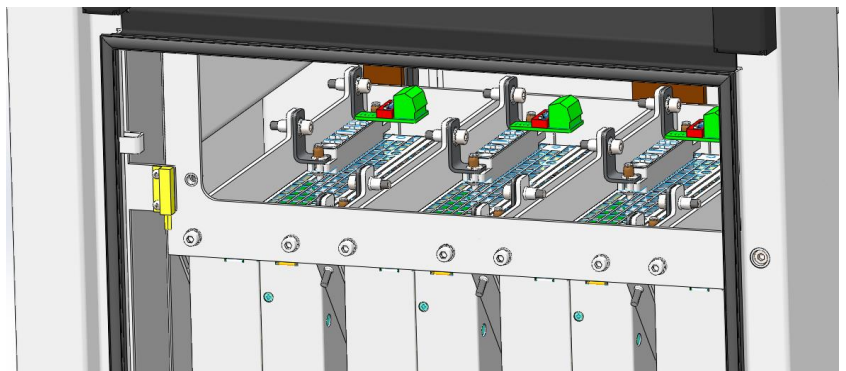


Figure 5.19. Connecting modules

12. Fasten the module bracket with the previously removed fasteners.
13. Repeat steps 5-12 for the second, third and fourth power modules.
14. Install and fasten previously removed protective panels 1 and 2.
15. Close the Door 1.
16. To install the top level modules (Door 2) repeat steps 4-15 for Door 2 (fig. 5.20).



Figure 5.20 Place of installation of modules in door 2

## 5.6. SETTING ADDRESSES OF CHARGING MODULES

1. Apply power to the station.
2. Turn the circuit breakers to the “ON” position.
3. Wait for the module to start operating – “SLP” indication.
4. Use the down button to select the parameter you want to set.
5. When selecting parameter “A00”, you must hold down the “down” button until you enter edit mode (the value flashes).
6. Change the module address using the up/down buttons. Addresses in modules cannot have the same meaning.
7. Once the address is set, press and hold the down button until the parameter stops flashing. This action will save the changes to the settings.
8. Select parameter “G00”, you must hold down the “down” button until you enter edit mode (the value flashes).
9. BE SURE to set it to "G01" for all modules. All modules must have the same value for this parameter.
10. After setting the parameter, press and hold the down button until the parameter stops flashing. This action will save the changes to the settings.
11. Repeat steps 1-10 to set the address for each module separately. If you did not have time to assign an address, turn off the station and start from step 1.

## 5.7. TURNING ON THE STATION



### ATTENTION!

**Before turning on the station, contact technical support to activate the SIM-card.**

To turn on the station, you must:

- Install a SIM card from your mobile operator:
  - remove the modem cover (Fig. 5.21);
  - install a SIM card;
  - close the modem cover.
- Install circuit breakers and residual current devices (RCDs) in the operating position (up).

Set the switch (outside the station) of the switchgear to the operating position (up).

The station is ready for use when the available connectors appear on the display (see chapter 6, Figure 6.1).



Рисунок 5.21. Installing a SIM-card into the GSM-module

## 5.8. CONNECTION OF THE STATION TO THE INTERNET NETWORK

The selection of the type of connection to the Internet is carried out using the mobile application "CS Service app" (available on Google Play and AppStore).

1. After installing the application on the mobile device, launch the application.

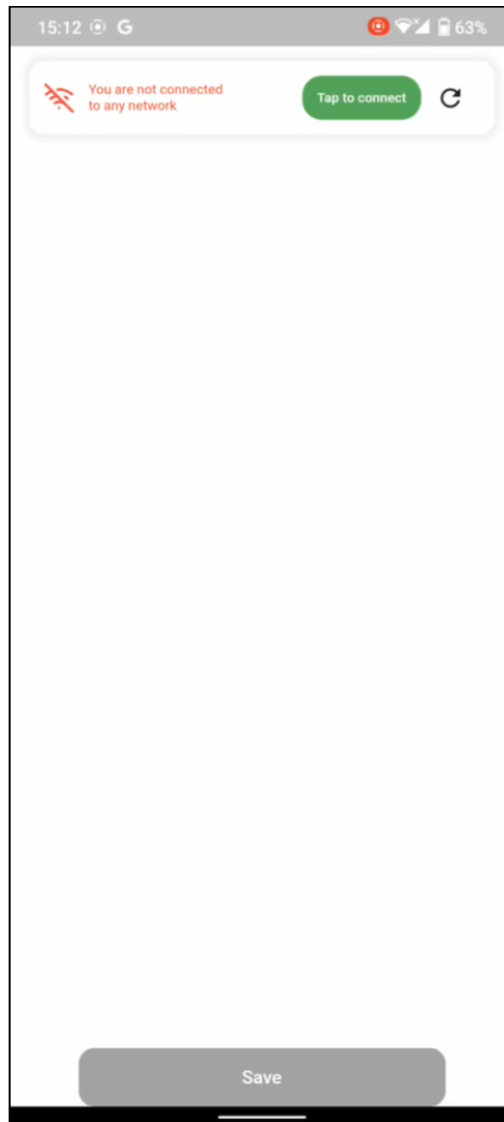


Figure 5.22. Selecting a device to configure via the app.

2. 2. Click on the Tap to connect button to go to the system window of the Wi-Fi network selection device.
3. 3. Select a Wi-Fi network with a name corresponding to the modem number.
4. 4. Enter the password - 2536789H
5. 5. Return to the application and in the "InternetSource" section (Figure 5.23) select the type of network that the station will use (wifi/lan/gsm).
6. 6. When connecting the station to Wi-Fi, in the Connect to Access Point and Access Point Password sections, enter the network name and network password, respectively.
7. 7. If you need to manually configure Wi-Fi or LAN parameters, turn the corresponding checkbox into inactive mode.



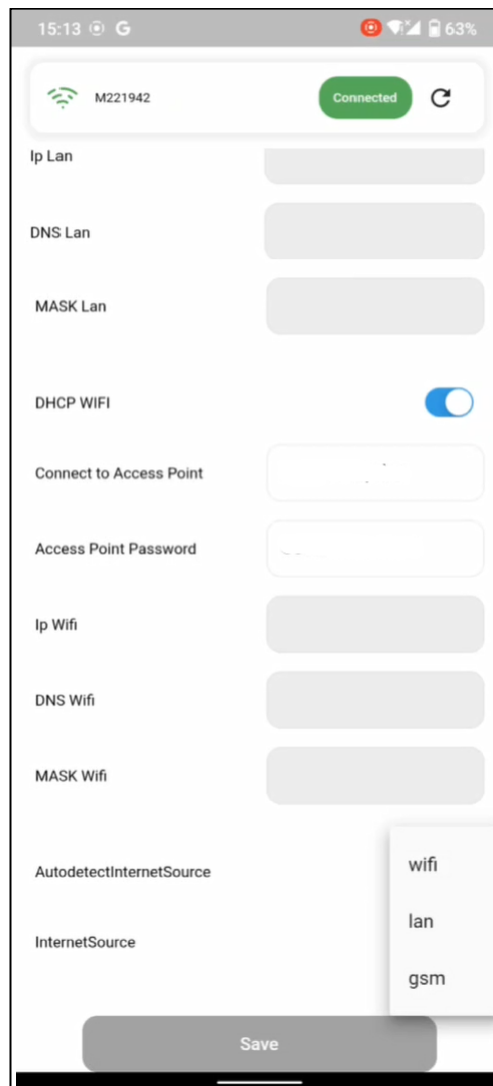


Figure 5.23. The window for selecting and setting the connection type for connecting to the Internet

8. Click the "Save" button to save the setting.

## 6. EXPLOITATION

### 6.1. OPERATION AND CHARGING MODES OF ELECTRIC VEHICLES

The display shows information about the operating modes of the charging station (the state of the connectors and charging parameters).

The information displayed on the display depends on the software version and may differ slightly.

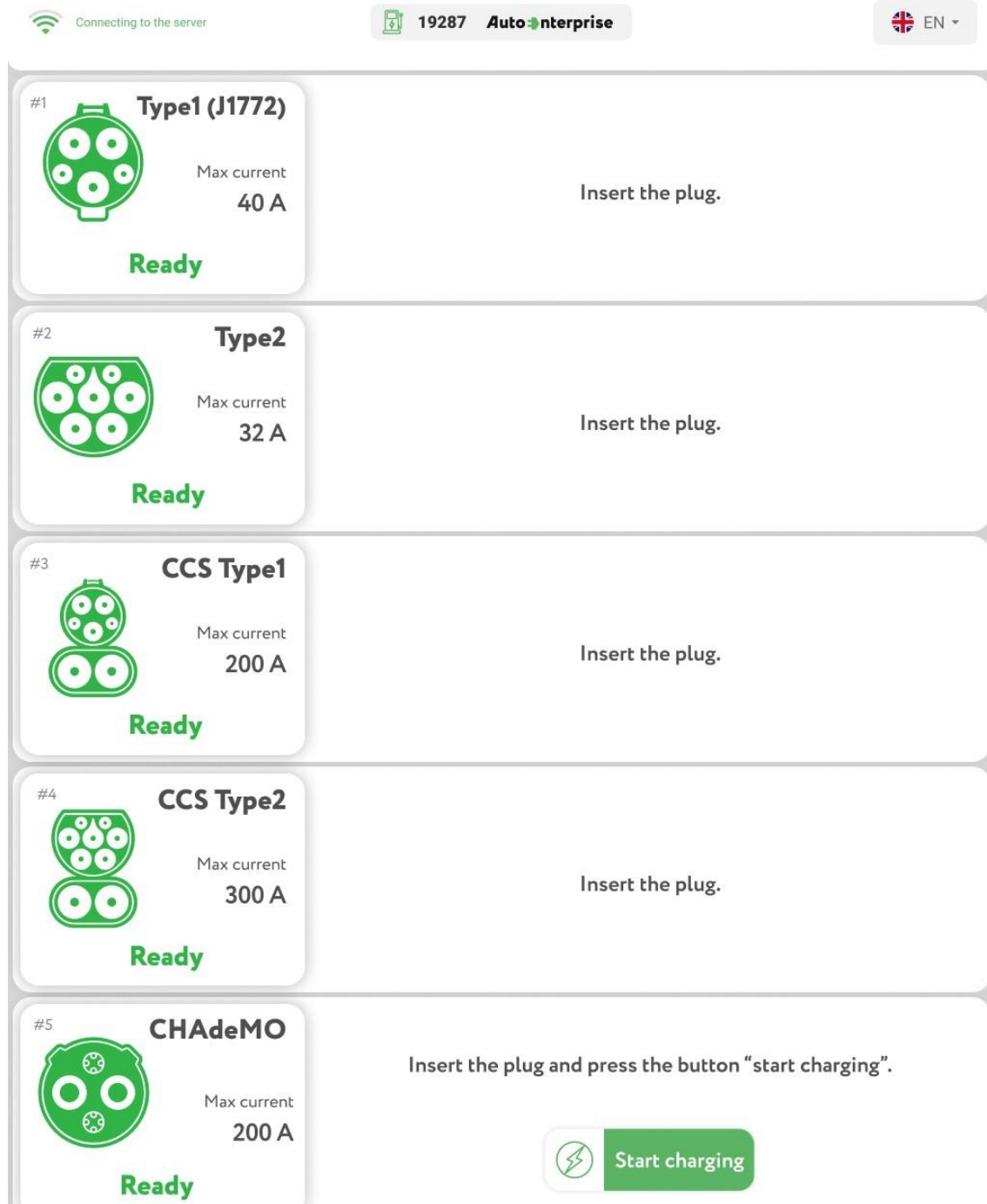


Figure 6.1 Screen display of a ready-to-use station

The station is ready for operation (Figure 6.1). The top line contains general information about the status of the station: indication of communication with the server, station number and name of the network of the charging station, interface language. This bar stays at the top of the screen when you scroll down.

Below is a list of installed connectors (depending on the configuration from 1 to 6) and their status. In Figure 6.1, all connectors have the Ready status - the connector is in working condition

and can be used to charge an electric vehicle. Next to it there is a hint for the user - "Insert the connector and press the button "Start charging".

When the user has connected the connector, its color on the display changes to blue: the user is authorized (Figure 6.2), and then the charging process takes place: the color of the plug changes to yellow, the status changes to "Charging" (Figures 6.2, 6.3).

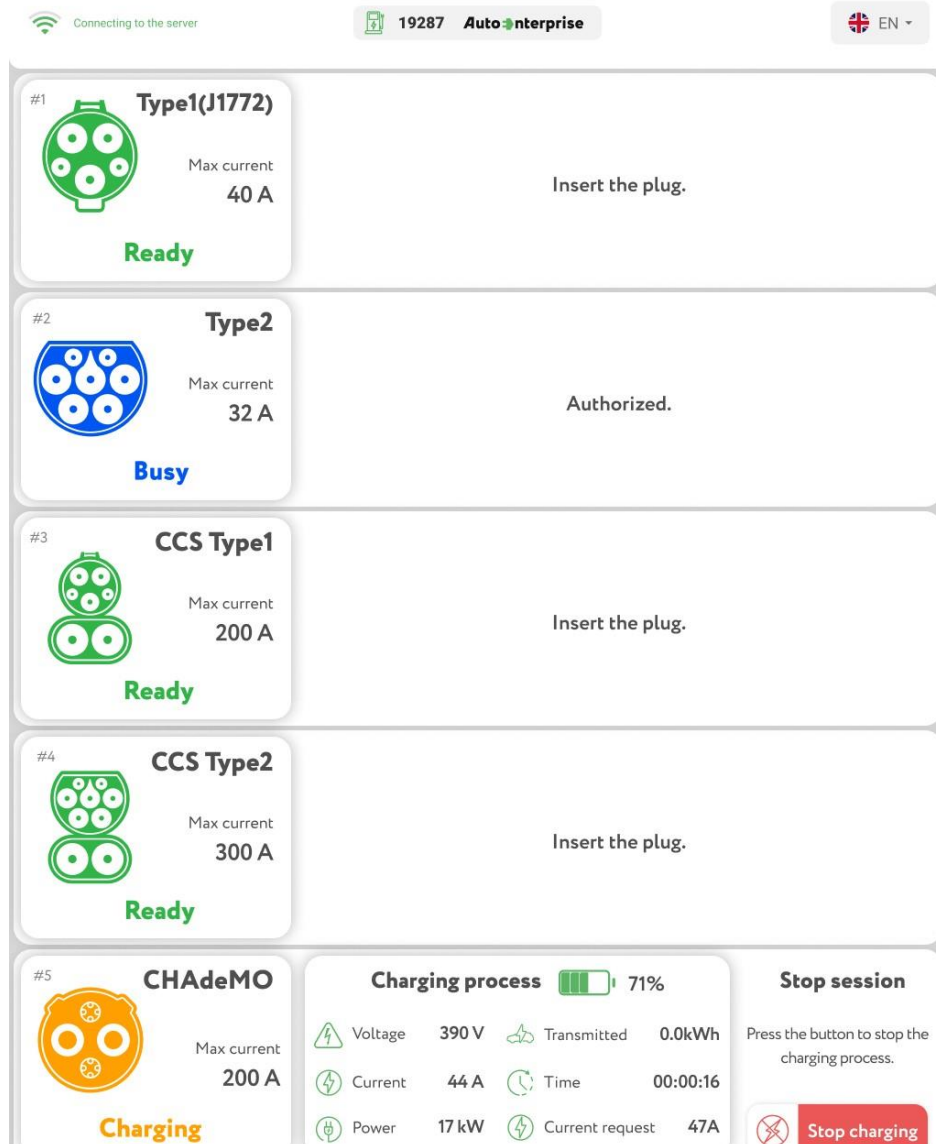


Figure 6.2 Display of the charging process on the station screen

During charging, the current parameters of the charging process are displayed on the screen: voltage, current and capacity of the connector, current desired by the electric vehicle, charging time and the amount of received energy in kWh.

When the battery of the electric vehicle is fully charged, the charging process ends automatically. If the connector is not removed immediately after that, the parking time will begin (Fig. 6.3). The cost of parking is determined by the owner (operator) of the station.

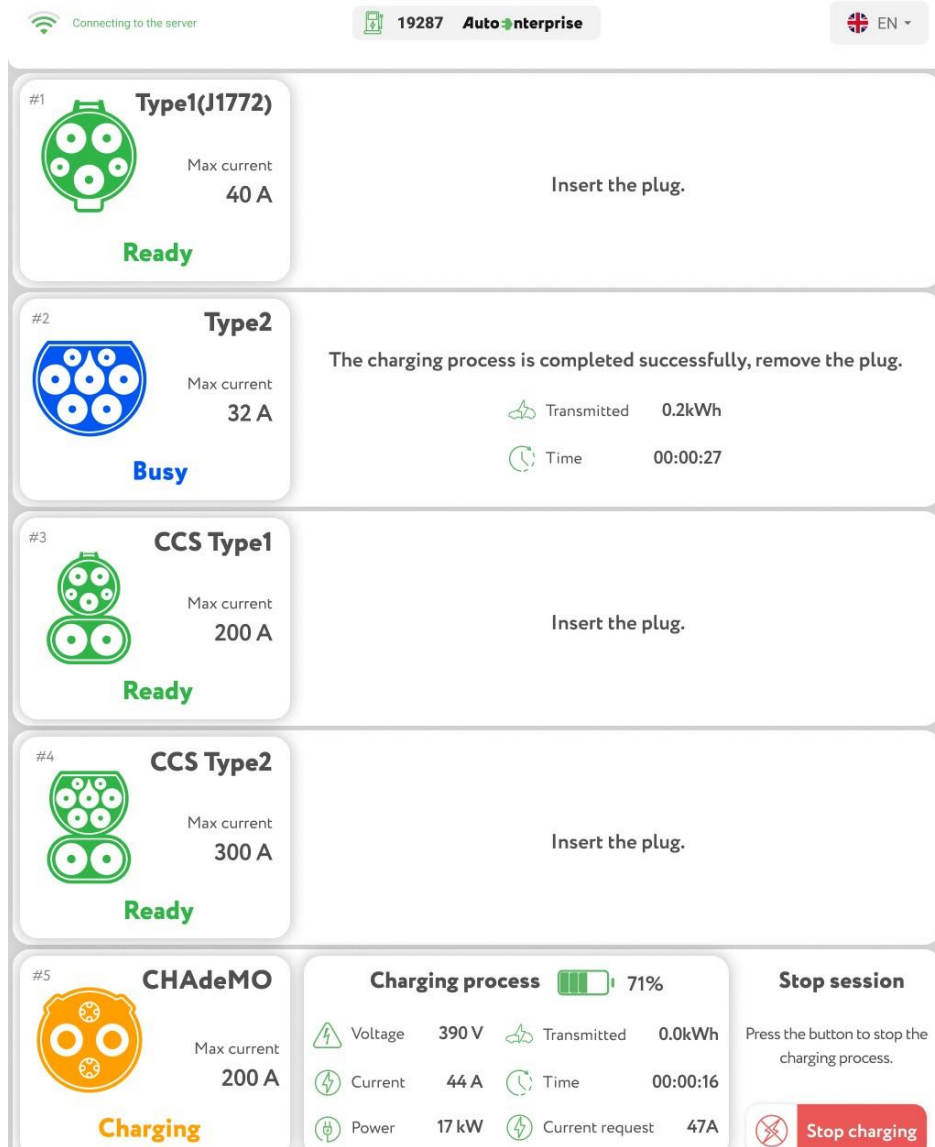


Рисунок 6.3 Відображення на екрані завершені зарядки автомобіля

Figure 6.4 shows an example of a station screen with the configuration Type 1, Type 2, CCS Type 1/CCS Type 2, CHAdeMO. At the same time, Type 1, Type 2, CHAdeMO connectors are free and available for use, CCS Type 1 is in charging mode, CCS Type 2 is unavailable.

Figures 6.5 and 6.6 show the possible screen views in the event of a CCS connector error and when the emergency stop button is pressed.

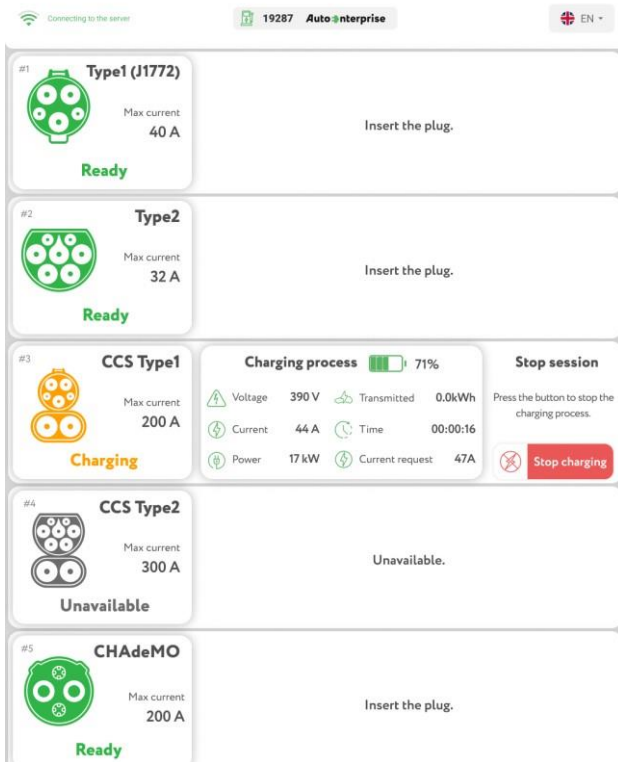


Figure 6.4. Displaying the unavailability of the connector

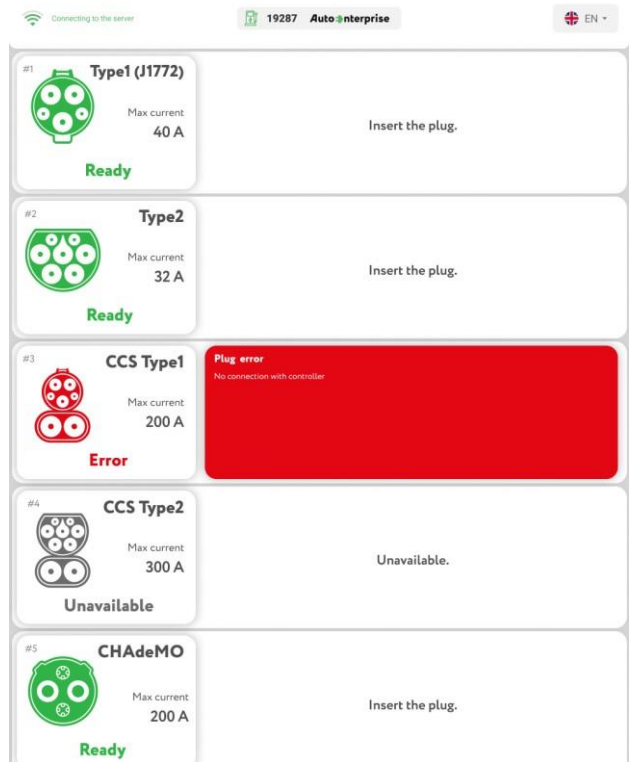


Figure 6.5. Display connector error

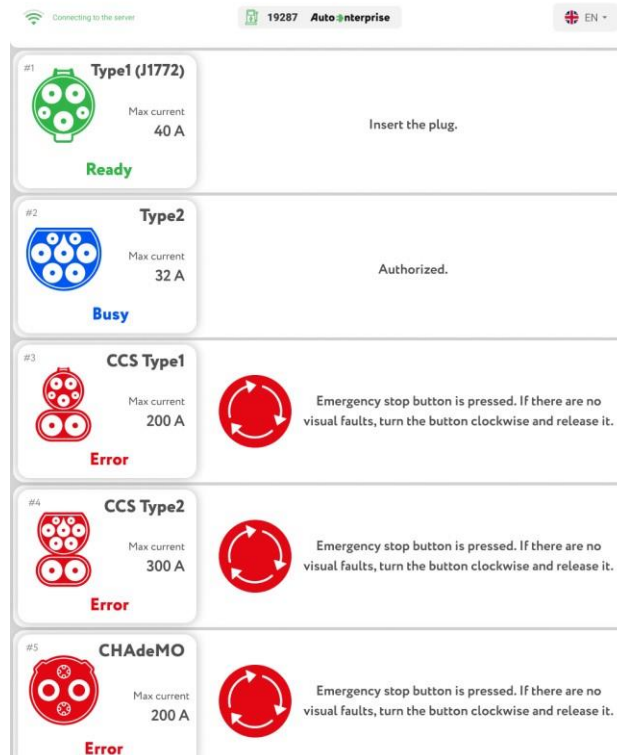


Figure 6.6. The emergency stop button is pressed

Table 6.1. Symbols on the station screen




















	Server connection connected/not connected.
 <b>19287</b> <b>AutoEnterprise</b>	The number of the charging station in the network of charging stations, the name of the network.
	Selection of interface language
	Start charging
	Stop charging
	Battery charge level of electric vehicles
 voltage	Current voltage
 current	Current at the moment
 power	Power at the moment
 Submitted	Charged battery capacity
 time	Charging time
 current request	Current required by an electric car at the moment.
	Type 1 connector in various states (see table 6.2)
	Type 2 connector in various states (see table 6.2)
	GB/T AC connector in different states (see table 6.2)
	CHAdeMO connector in different states (see table 6.2)
	CCS Type 1 connector in different states (see table 6.2)
	CCS Type 2 connector in various states (see table 6.2)
	GB/T DC connector in different states (see table 6.2)

Table 6.2. Connector status

Status	Color	Explanation
Ready	Green	The status "Ready" means that the connector is free (the electric car is not charging at the moment) and is available for charging the electric car.
Busy	Blue	The status "Busy" means that the connector is already connected to the electric vehicle and indicates several modes: <ul style="list-style-type: none"> <li>- the station is preparing to start charging. This may include checking the connection between the charging connector and the electric vehicle and the compatibility of the charging parameters;</li> <li>- the charging session has ended, but the connector has not yet been disconnected. Parking time is taken into account (the parking fee is set by the station owner);</li> <li>- the download is temporarily suspended. This can be for various reasons, for example, if the owner of the vehicle decided to manually suspend the charging, or due to technical problems.</li> </ul>
Charging	Yellow	The status "Charging" means that the electric vehicle is connected to the charging station and is being charged. In this mode, information about the charging speed and the amount of transferred energy is displayed.
Error	Red	The "Error" status means that the connector is not available for use for some reason. The reasons could be technical faults, pressing the emergency stop button, connector reset, or the need for regular maintenance or repair. An "error" is accompanied by an appropriate textual and/or graphical explanation (for example, an error code).
Unavailable	Gray	The status "Unavailable" means that the connector is not available for charging. This can happen during station startup/reboot when the system cannot determine the current state of the connector, or when the DC connectors are in "OR" mode and one of them is charging.

## 6.2 START OF CHARGING

To start the car charging process, follow these steps:

1) Connect the connector, in the "Ready" status, to the car (the order of attaching different connectors is described in section 6.3)

2) Log in

Authorization is possible:



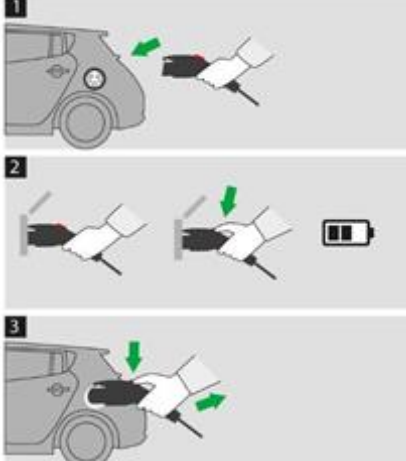


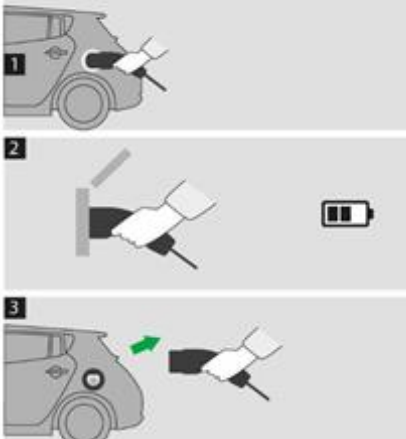


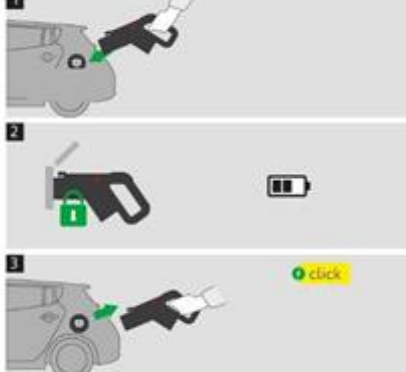


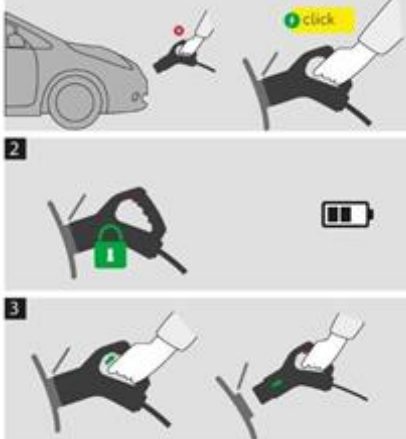
- through the application (the name of the program depends on the system operator)
- using a special card
- using the terminal (if available)
- automatically if the car has a chip tag

After authorization, the process of charging the car will begin.



### 6.3. CONNECTING THE VEHICLE

 <p>CCS Type 1 connector</p>	   
 <p>CCS Type 2 connector</p>	   
 <p>GB/T DC connector</p>	   

 <p>Type 1 connector</p>	  <p>1</p> <p>2</p> <p>3</p>
 <p>Type 2 connector</p>	  <p>1</p> <p>2</p> <p>3</p>
 <p>GB/T AC connector</p>	  <p>1</p> <p>2</p> <p>3</p> <p>click</p>
 <p>CHAdeMO connector</p>	  <p>1</p> <p>2</p> <p>3</p> <p>click</p>

## 6.4 END OF CHARGING

Stopping the charging process by the user is done by pressing the "Stop charging" button on the screen, by pressing the corresponding button in the car or in the application, *for CCS Type2 connectors, CHAdeMO it is possible to disconnect the charging by pressing the button on the connector itself.*

The emergency stop is performed by pressing the button of the emergency device (Description of the operation of the emergency stop button is considered in paragraph 8.2).

It is allowed to remove the connector from the car only after the message "The charging process is successfully completed, disconnect the connector" appears on the display. The process of disconnecting the connector from the car is the reverse of connecting it.

## 7. MAINTENANCE



### ATTENTION!

All maintenance work must be performed by the manufacturer's representative or a qualified technician. Do not attempt to perform routine maintenance yourself; this may result in electric shock and/or loss of functionality of the charging station.

Improper maintenance may result in serious injury or equipment damage. For this reason, this work should only be performed by authorized, trained personnel who are familiar with the operating principles of the plant and strictly follow all safety instructions.

The use of explosive or flammable cleaning products poses a risk of fire or explosion.

Do not store flammable or explosive liquids near the charging station.



### WARNING!

Before carrying out any maintenance work, ensure that the charging station is de-energized.



### INFORMATION

To ensure maximum service life of the charging station, it is recommended that the interior be kept clean regularly.

Before starting any maintenance or cleaning work on the charging stations or circuits connected to the charging station, service personnel must disconnect all AC sources from the charging station to avoid the risk of electric shock.

It is strictly forbidden to modify or change the design of the Charging Station in any way without the written consent of the Manufacturer!

### 7.1 SERVICE

- 1) The following actions must be performed before each service:
- 2) 1) Disconnect the station from the voltage source.
- 3) 2) Thoroughly clean the case, contacts and ventilation holes from dust and dirt.
- 4) 3) Check the quality of cable fastening. The terminal block screws and wire ends must be tight and the insulation must not be damaged.
- 5) 4) Replace all damaged or illegible signs, inscriptions, icons.

Work plan for maintenance of the charging station:

Every 3 months:

- Visual inspection of the station for integrity and mechanical damage;
- Cleaning the station from dust and dirt;
- Checking the integrity of charging cables, connectors and cable holders;

- Replacement of filters (chapter 7.2).;
- Visual inspection of damaged parts, assemblies, their repair and replacement.

#### Every 12 months:

- Checking the tightening torque of the screws on the PDD contacts (3-5 N·m).
- Checking the protective disconnection device (PDD)

The PDD is checked by the "Test" button on the PDD unit, which allows the user to check the correct operation of the device by passing a small current through the PDD unit. This simulates a fault by creating an imbalance in the measuring coil. If the PDD does not work when this button is pressed, the device must be replaced (chapter 7.3) by a qualified specialist. The device must also be replaced when the PDD has tripped, but it is not possible to return the switch to the active position. Audit results must be documented.

#### Every 36 months:

- Checking the PDD using special testing equipment or in a specialized laboratory, where parameters of voltage, current and operation time are taken into account. For this purpose, the PDD (chapter 7.3) is first dismantled from the station and replaced with a similar, known serviceable one.
- Circuit breakers are checked using special testing equipment or in a specialized laboratory, where voltage, current and trip time parameters are taken into account during the tests. For this, the automatic circuit breaker (specified in chapter 7.3) is first dismantled from the station and replaced with a similar one that is in good working order.
- Checking the tightening torque of the screws on the PDD contacts (3-5 N·m). On the contacts of the automatic switches (3-5 N·m) and the terminal board of the station inputs (M12 - 40-50 N·m; M8 - 10-11.9 N·m).
- Include inspection results in relevant documentation.

## 7.2. FILTER REPLACEMENT

Station filters should be replaced at least once every 6 months. In the case of operation of the charging station in conditions of increased dustiness, it is recommended to carry out extraordinary regular maintenance, which consists in preventive cleaning of the internal elements of the Station from dust at least once every 3 months.

Filters are installed in doors 1 and 2. It is necessary to replace them:

1. Open door 1 (Figure 4.1).
2. Unscrew nuts 1 around the perimeter of the safety net (Figure 7.1a), remove the safety net.

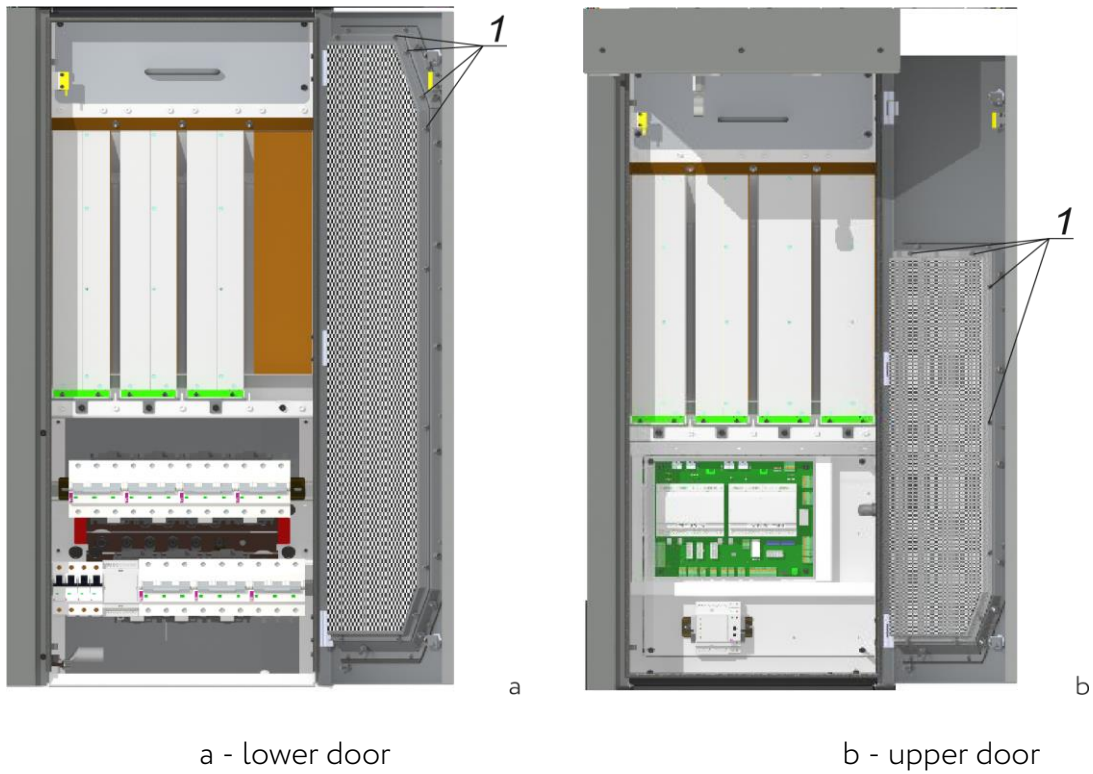


Figure 7.1 Location of filters

3. Remove the filter element.
4. Prepare a new filter in advance according to the given dimensions (Figure 7.2a). It is recommended to use filter material G3 15 mm.

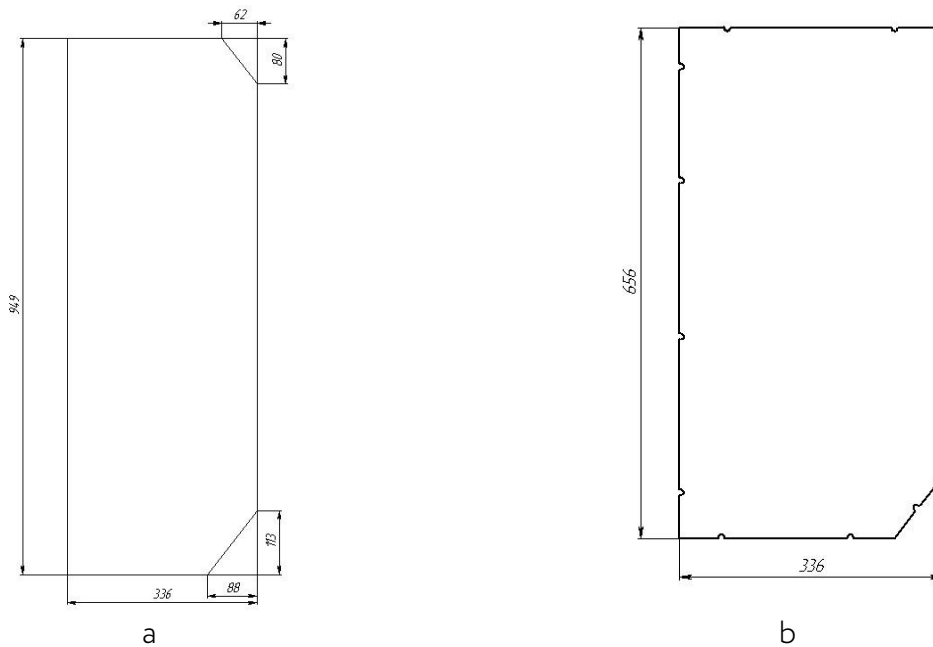
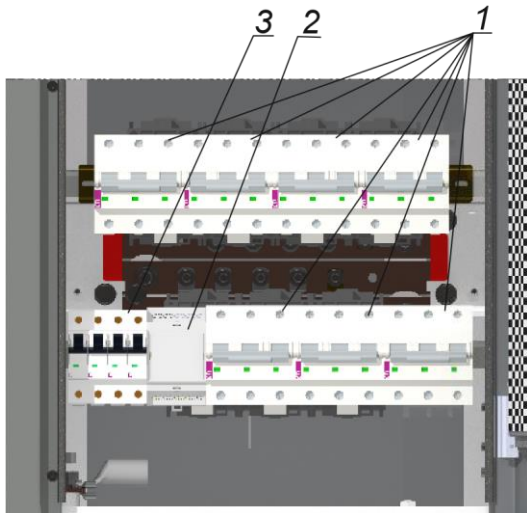


Figure 7.2 Dimensions of filter elements

5. Clean the protective net and door 1 from the inside.
6. Reassemble in the reverse order.
7. Repeat steps 1 to 6 for door 2 (Figure 7.1b, Figure 7.2b)

### 7.3. REPLACEMENT OF SWITCH, PROTECTIVE DISCONNECT DEVICE

1. De-energize the station.
2. Open the door 1 (Figure 4.1).



- 1 – protective disconnection devices;
- 2 – input relay control unit;
- 3 – power switches of 12 V power supply units.

Figure 7.3. Electric circuit breaker panel

3. Disconnect the input and output wires from the automatic switch (protective disconnection device).
4. Dismantle the automatic switch (protective disconnection device).
5. Install a new switch (protective disconnection device) with similar parameters.
6. Connect the input and output wires to the automatic switch, PDD, tightening bolt (3-5 N·m).

### 7.4. REPLACEMENT OF INPUT RELAYS WITH AC/DC INVERTERS

Input relays are located in the lower part of the station.

In order to replace the relay, it is necessary to perform the following actions:

1. Make sure that the station is de-energized.
2. Open door 3 (Figure 4.1).
3. Remove fasteners 1, 2, 3, 4, 5, 6 and remove the hatch (Figure 7.4).
4. Disconnect the input cable from the input terminal busbars.



Figure 7.4 Relay compartment hatch

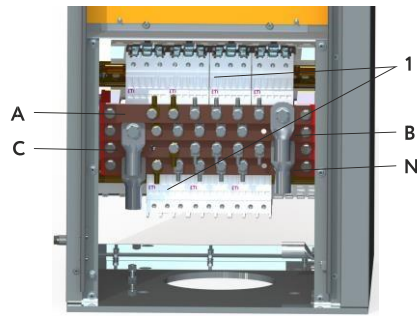


Figure 7.5 Relay and bus compartment

4. Using a 13 mm wrench, remove rails A, B, C, N (Figure 7.5 a, b: 1 - input relays of the inverter).
5. Disconnect the contactor wires.
6. Replace the contactor.
7. Connect the wires.
8. Install rails on the input socket.
9. Connect the input cable to the bus.
10. Close the hatch and fasten it with previously removed fasteners.
11. Close the door.

## 7.5. INSTALLATION, REPLACEMENT, REPAIR OF CABLE TENSIONERS

1. Unscrew 6 screws 1 (Figure 7.6).

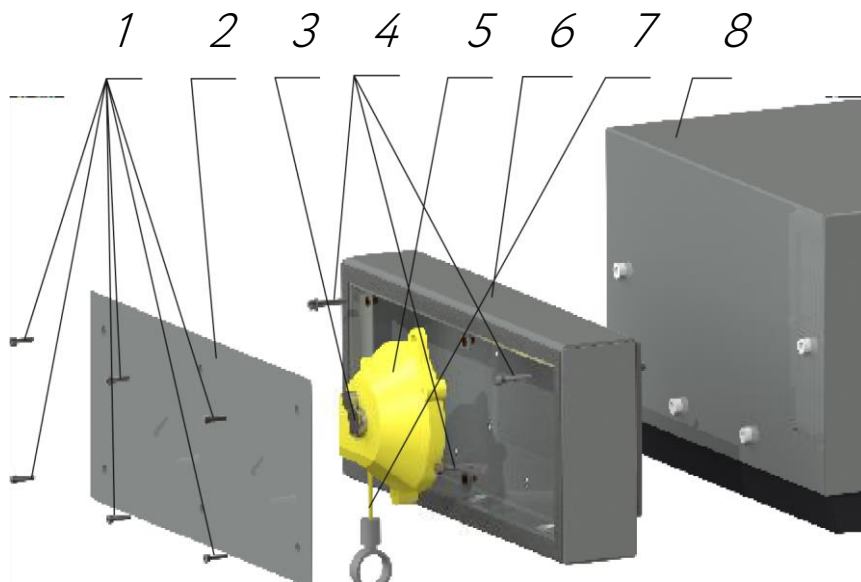


Figure 7.6 Fastening of cable tensioners

2. Remove cover 2. (Figure 7.6).



3. Unscrew the tensioner bolts 5 (Figure 7.6).
4. Unscrew the screws on the tensioners 5 (Figure 7.6) and remove the back cover.
5. Unwind the cable.
6. Remove the rope from the fastening on the drum, pull out the rope.
7. For assembly. Before that, disassemble the tensioner 5 (Figure 7.6) and remove the cable from the tensioner.
8. Pull the cable through the entrance hole in the housing 6 (Figure 7.6) and into the holder case.
9. Attach the rope to the drum and put the drum back in place together with the spring.
10. Screw the cover of the tensioner case.
11. Attach the tensioner to the body 6 (Figure 7.6).
12. Set the required tension by turning screw 3 (Figure 7.6) as needed (cable attachment).
13. Attach cover 2 (Figure 7.6).
14. Tighten screws 1 (Figure 7.6).

## 7.6. REPLACEMENT OF THE DIRECT CURRENT RELAY

1. Unscrew screws 1 (Fig. 7.7).

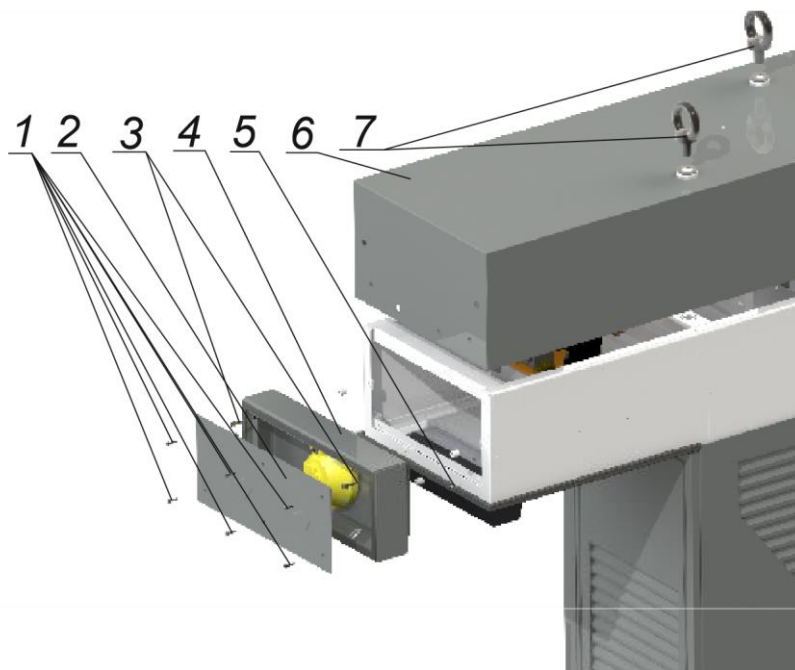


Figure 7.7. Location of the DC relay

2. Remove cover 2 (Figure 7.7).

3. Unscrew screws 3 (Figure 7.7).
4. Remove the cable holder 4 (Figure 7.7).
5. Unscrew screws 5 (Figure 7.7).
6. Unscrew the eye with bolts 7 (Figure 7.7).
7. Repeat steps 1 through 5 for the other side of the upper station.
8. Remove cover 6 (Figure 7.7).



### WARNING!

Remove the cover and disconnect the backlight power connector.

8. Unscrew nuts 2, remove tires (Figure 7.8).
9. Unscrew screws 1 (Figure 7.8), disconnect the wires, remove the relay.
10. Assemble in reverse order.

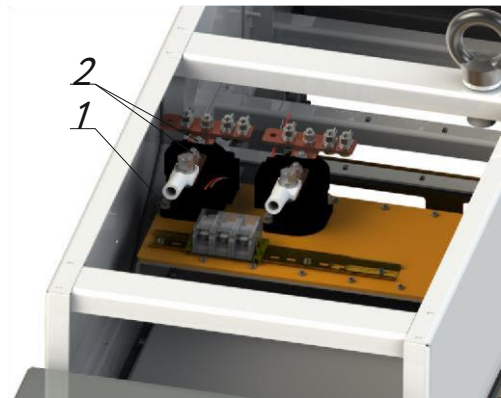


Figure 7.8. Direct current relay

## 7.7. REPLACEMENT OF CHARGING CABLE WITH CONNECTOR

1. Remove the cover as described in section 7.5.
2. Unscrew the cable lugs 1 (Figure 7.9).
3. Disconnect the low-voltage connector from the cable.
4. Unscrew the cable entry nut 2 (Fig. 7.9).
5. Pull out the cable with the plug.

6. Install the new cable in the reverse order.

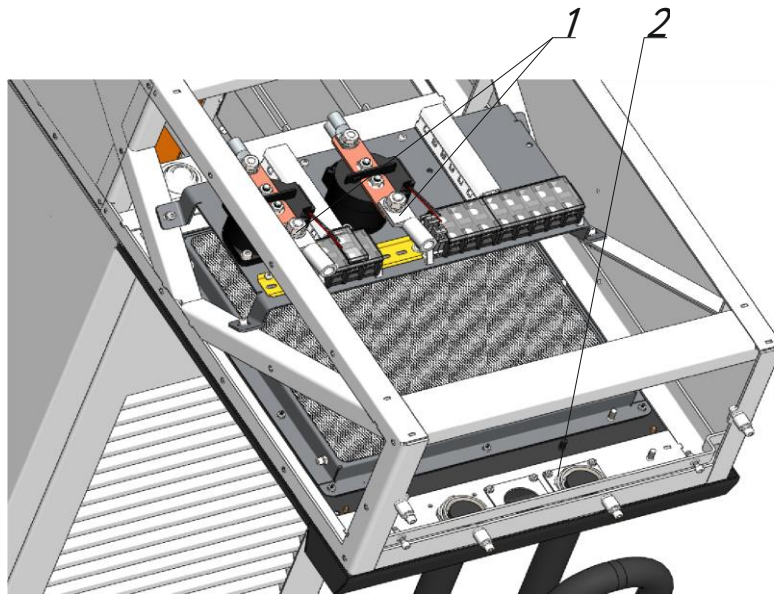


Figure 7.9 Connecting the connector cable

## 7.8. DISPLAY REPLACEMENT

1. Open doors 1-4 of the charging station (Figure 7.9).
2. Disconnect the power and RS485 interface connectors from the screen.
3. Unscrew nuts 1 (Figure 7.10).
4. Unscrew the stops.
5. Disconnect the screen from the silicone sealant by pressing on it from the inside (Figure 7.11).
6. Remove the screen.

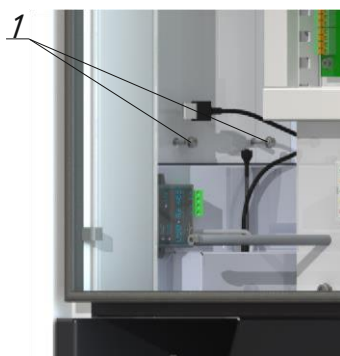


Рисунок 7.10 Кріплення екрану



Рисунок 7.11 Видалення екрану

7. Before installation, apply silicone sealant around the perimeter of the screen.
8. Assemble in reverse order.

## 7.9. INSTALLATION, REPLACEMENT OF CHARGE CONTROLLERS

1. Open door 2 (Figure 4.1).
2. Controllers 3, 4 (Figure 7.12) are installed on the board (marked as EVCC-CH-XXX, EVCC-CCSXXX, EVCC-GBT-XXX, EVCC-AC-XXX). To replace the charge controllers 3, 4 (Figure 7.12), they must be pulled out by pulling them to the opposite side of the board.
3. To install, insert the controller into the connectors on the board.

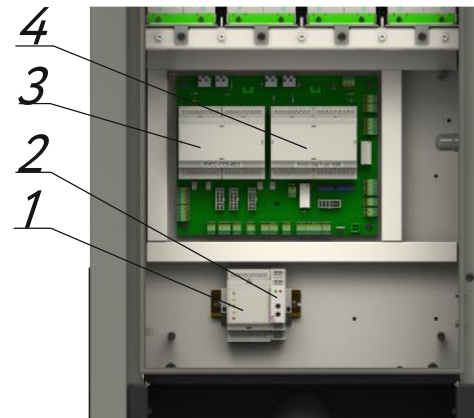


Figure 7.12. Charge controllers

## 7.10. MODEM REPLACEMENT (EVCC-4G)

Removing modem 1:

1. Disconnect the cables at the bottom of the device, disconnect the connectors, remove the device from the DIN rail.
2. Assemble in reverse order.

## 7.11. TWILIGHT SWITCH ADJUSTMENT

The twilight relay (Figure 7.13) is installed on a DIN rail. Its location depends on the configuration of the station. For example, at the station (Figure 7.12), the relay is located next to the modem.

The setting is carried out by the following elements:

- DELAY – setting the response time;
- LEVEL – adjustment of sensitivity.



Figure 7.13. Twilight switch

## 7.12. REPLACEMENT OF POWER MODULES

1. The procedure for installing modules on the station is described in chapter 5.3.1. The same procedure should be used to replace the module, but first the module to be replaced must be removed.
2. 1. Make sure the station is powered off.
3. 2. To replace the station module, it is necessary to open door 1 or door 2, depending on the position of the module (Figure 5.4).

4. 3. Remove the module to be replaced. To do this, you need to remove the latches on the support of the module (section 5 of chapter 5.3.1) and connectors 1 and 2 (section 10 of chapter 5.3.1), remove connectors 1 and 2 and remove the module from the panel.
5. 4. Install the new power supply according to the instructions in section 5.3.1.
6. 5. Close the door.

## 8. TROUBLESHOOTING

### 8.1. ERRORS DISPLAYED ON THE SCREEN OF THE STATION

Error	Error description	Solution of the problem
Contactor Failed	Contactor error.	Replace the output contactor.
CP Error	Signal transmission error in SR between the charging station and the vehicle.	<ol style="list-style-type: none"> <li>1. The connector is inserted incorrectly. Reconnect to the vehicle.</li> <li>2. Damaged connector or cable, broken SR line.</li> <li>3. Replace the connector and cable.</li> </ol>
Current Sensor Fault	The output contactor is jammed.	Replace the output contactor.
EEPROM Error	EEPROM memory error.	Replace the system EEPROM with EVCC-4G.
EMO Pressed	The emergency stop button is pressed.	Release the emergency stop button.
Inoperative	The connector is not available.	<ol style="list-style-type: none"> <li>1. The charge controller has entered Unavailable mode because the inverters are busy with another controller.</li> <li>2. The charge regulator is disabled.</li> </ol>
No Input Voltage	There is no voltage at the input of the charging station.	Apply voltage to the input.
No Meter Found	The controller is not connected to the meter.	When using an internal meter, check the RS485 connection between the EVCC-4G and the charge controller.
Over Current	Exceeding the current limit	Further diagnosis is required. Contact support.
Power System Fault	Charging error (Connector).	<ol style="list-style-type: none"> <li>1. Check the power modules.</li> <li>2. Check the CAN line from the controllers to the power modules.</li> </ol>
SIM Failure	SIM card error.	Erase the contacts of the card or replace it.
Vehicle Failed	Vehicle error.	Charging stopped at the side of the vehicle due to a malfunction in the vehicle.

Voltage Is Too High	High voltage input.	Make sure the voltage value is correct
Voltage Is Too Low	Low voltage input.	Make sure the voltage value is correct
Error	Error description	Solution of the problem
Internal Error	Internal driver error.	Replace the driver.
Battery Overvoltage	High voltage on the car battery.	The charging station does not support the voltage of the car battery.
CAN Error	There is an error in the CAN line between the car and the charging station.	<ol style="list-style-type: none"> <li>1. The connector is connected incorrectly. Reconnect to the vehicle.</li> <li>2. The CAN cable between the charging station and the car is damaged. Replace the connector and cable.</li> <li>3. The controller is damaged. Replace the charge controller.</li> </ol>
Charger Error	Charging station error.	Replace the charge regulator.
Current Deviation	Incorrect current supplied by the inverters on demand of the vehicle.	<ol style="list-style-type: none"> <li>1. Check the inverters.</li> <li>2. Make sure the output wires between the inverter and the contactors are securely connected.</li> </ol>
Deauthorized	Authorization error.	Check the connection to the server.
Ground Failure	Ground fault.	Make sure the charging station is well grounded.
Overvoltage Detected	Overvoltage at the connector.	This can happen if charging stops at a high current or indicates a malfunction of the power modules or battery of the electric vehicle. Further diagnosis is required. Contact support.

PLC Session Fault	PLC modem error.	This can happen in CCS controllers. There is an error in the transmission of data between the vehicle and the CCS controller via the PLC modem. Replace the PLC modem in the CCS controller. The signal level of the car does not match the signal level of the charging station.
RCD Error	An error in the current leakage measurement system.	Electricity leakage detected. Eliminate the leak.
Error	Error description	Solution of the problem
No connection	Modem failure / SIM card failure. Weak cellular signal level / GSM-modem antenna malfunction / Location of the station outside the coverage area of the mobile network.	Replacing the GSM-modem or checking the status of the SIM-card. Replacing the antenna with a more powerful one.
Vehicle System Fault	Charging error	Contact a car service.
Voltage Deviation	Incorrect outputs of the inverter on the car.	Checking inverters
Stopped with Error	Charging stopped by mistake.	Replace the charge regulator. Check the inverters.
Tamper Error	Door opening error.	Close the charging station door.
Veh Battery Error	Car battery error.	Contact a car service.
Veh Contactor Fault	Vehicle contactor error.	Contact a car service.
Veh Normal Stop	Charging stops on the side of the car.	1. Turn off the car before charging. 2. Contact the service center.
Vehicle Error	Error on the part of the car.	Contact a car service.
Power Modules Error	Inverter error.	The controller cannot find the inverters. 1. Check the operation of the inverters. 2. Check whether the



supply voltage is supplied to the inverters.

3. Check the contactors at the inverter input.

Check the contactor switchgear.

## 8.2 EMERGENCY STOP BUTTON

The emergency stop button in DC charging mode is located on the left panel with connectors (side panel of the station to the left of the display) (Figure 4.1).

When the emergency stop button is pressed in the DC charging mode, the electrical network that charges the battery of the electric vehicle is interrupted. At the same time, the message "Emergency stop button" appears. If there are no visual defects, turn the button clockwise and release it. (Figure 8.1).

To continue operation of the Station, it is necessary to manually return the emergency stop button to the initial state (turn clockwise).

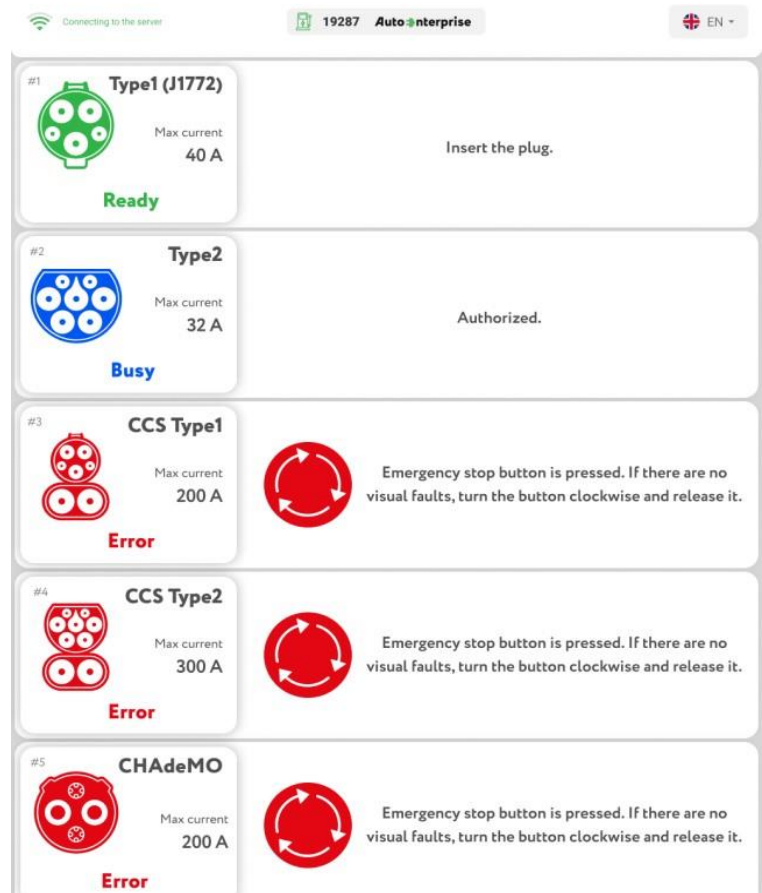


Figure 8.1. The emergency stop button is pressed

## 8.3. TECHNICAL SUPPORT

You can write an email or call to the tech support using the contact page on our web-site:

[evachargers.com](http://evachargers.com)

For a quick solution to the problem, report the station modem number or the station number to EVA CHARGERS support.

## 9. STORAGE

The charging station is supplied in individual factory packaging. Remove all packaging before installing the station.

### STORAGE CONDITIONS:

- Charging station must be stored in its original packaging.

- Charging station should be stored in dry heated rooms, free of dust, corrosive and oily materials.
- Keep the charging station in the warehouse with the appropriate weather protection.
- Keep away any sharp object from the charging station, cords or plugs/connectors.
- During storage, the charging station must be protected from shocks.
- Avoid extreme temperature fluctuations.
- Storage temperature range: 5 °C to +40 °C (41 °F to 104 °F).
- Humidity: < 75%.

## 10. TRANSPORTATION

Charging stations must be transported in transport packaging by rail, road and air transport without limiting the transportation distance, taking into account the rules for the transportation of goods in force for these types of transport.

When transporting, consider the center of gravity of the charging station to minimize the risk of tipping over.

During transportation, the charging station must be reliably protected from movement inside the vehicle. To securely fasten the station, straps and soft inserts should be used, and measures must be taken to protect the station from damage by other transported objects.

## 11. DISPOSAL



### ATTENTION!

The symbol with the crossed-out waste container means that electrical and electronic devices including their accessories must not be disposed in the household garbage!

Please observe the regulations regarding disposal of electric appliances and electronic devices!

Electronic components of the charging station must be disposed in accordance with the current legislation regarding the disposal of electronic and electrical waste.

## 12. FAT CERTIFICATE

### THE CHARGING STATION

<small>PRODUCT NAME</small>	
<b>CHARGE COMPLEX-T</b>	<b>XXXXXXXXXX</b>
<small>MODEL</small>	<small>SERIAL NUMBER</small>
manufactured and accepted in accordance with the requirements of <b>EN 61851-1, EN 61851-23</b>	
and recognized as fit for use	
<small>STANDART</small>	

Head of Quality Control Department

LS

SIGNATURE

FULL NAME

DATE

### 13. MANUFACTURER'S WARRANTY

This Limited Product Warranty ("Warranty") applies to the charging station I-STATION ("Station") purchased from manufacturer or one of its authorized distributors.

Subject to the exclusions set forth below, manufacturer warrants that the Station will be free from defects for a period of one (1) year after the date of delivery manufacturer's warehouse ("Warranty Period"), unless manufacturer and its direct customer ("Customer") explicitly agree otherwise in writing.

Customer may transfer the Warranty to its customers ("Station's Owner" or "Owner").

#### WARRANTY SERVICE

Within the Warranty Period, upon verification of a warranty claim, manufacturer will, at its sole discretion, repair or replace broken component (that was damaged in normal use) at no charge to Owner for material and/or labour. Owner pays any transportation costs associated with the replacement / repair of components (to the manufacturer factory or any other repair location indicated by manufacturer).

If the repair issue cannot be resolved remotely, Owner shall, at its own expense, ship the Product(s) to a Repair Centre, after receipt of respective instructions.

To obtain the necessary instructions you must contact to Customer Service at [autoenterprise.ua](http://autoenterprise.ua).

Owner assumes risk of any shipping related loss or damage.

If the fault is covered by this Warranty, manufacturer will repair or replace the Product(s) and ship it back to the Owner via ground transportation at manufacturer's cost.

The out-of-warranty Station or station ineligible for warranty service will be repaired or replaced at Owner's request according to the preliminary agreement on payment and shipped back at Owners expense.

All replaced parts are the property of manufacturer.

The warranty does not apply to equipment damaged as a result of:

- incorrect electrical, mechanical connection;
- misuse or Station usage beyond its intended purpose;

- modification or changes in the design of the product without written manufacturer approval;
- incorrect installation, assembly/disassembly or relocation of the Station unless performed by manufacturer or authorized service personnel;
- maintenance and repair of product performed by an unauthorized or unqualified personnel;
- failures from the grid;
- external damages (including physical damage from being struck by a vehicle) or violation of the rules of transportation and storage;
- use of interfaces or parts not provided by manufacturer;
- accidents, acts of nature or other causes beyond manufacturer's control;
- vandalism.

The manufacturer is not responsible for the possible costs associated with the installation and removal (dismantling) of the warranty equipment, as well as for damage caused to other equipment in the possession of the consumer, as a result of malfunctions (or defects) arising during the Warranty period. Furthermore, damage to the electrical vehicle itself is never covered by this Warranty.

Manufacturer or its authorized distributors will not be liable for any indirect, incidental, special, punitive or consequential damages, even if manufacturer knew or should have known of the possibility of such damages.

The cumulative liability of manufacturer or its authorized distributors for all claims whatsoever related to this station or the service will not exceed the price of this station.

### ADDITIONAL INFORMATION

Owner is responsible for the proper installation and maintenance of the Station.

This Limited Product Warranty is not transferable by the Station's Owner to anyone else.

PC "AE FACTORY" reserves the right to update any information, illustrations, sheets, specifications and diagrams contained in these Manual at any time without prior notice in respect of technical developments.

All inquiries or claims made under this Limited Product Warranty must be address as follows:  
evachargers.com