



CHARGING STATION

«Single»



User Manual

© Copyright

This documentation with all illustrations is the intellectual property of the «EVA CHARGERS», Group of Companies. All documentation is provided to the user for personal use only. The entire documentation or any part of it cannot be reproduced or provided to others without the written permission of the developer. Any violation will be prosecuted.



All information, illustrations, tables, specifications, and diagrams contained in this Operating Instruction have been carefully compiled, in accordance with the state of the art at the time of publication. The Developer shall not be responsible for errors, missing information, and any subsequent damage or consequential loss.

The software has been designed and installed exclusively for the Charging Station operation and it should only be used for the purposes for which it was developed. The user is strictly prohibited from making any changes, transformations, or copying the software (except for necessary backups).

The Developer shall reserve the right to make changes regarding illustrations, tables, characteristics, and diagrams contained in this Operating Instruction at any time without prior notice to the consumers.

## TABLE OF CONTENTS

SAFETY PRECAUTIONS.....	4
1 GENERAL INFORMATION.....	6
1.1 APPLICATION.....	6
1.2 CHARGING STATION FUNCTIONALITIES.....	6
1.3 TECHNICAL CHARACTERISTICS .....	6
1.4 CHARACTERISTICS OF THE STATION CONNECTORS .....	8
1.5 CHARGING STATION MODIFICATIONS.....	9
1.6 APPEARANCE AND DIMENSIONS OF THE CHARGING STATION .....	9
2 COMPLETESET .....	10
3 LABELLING AND MARKING .....	10
4 SETTING-UP PROCEDURES.....	11
4.1 OPERATING RESTRICTIONS .....	11
4.2 CHARGING STATION MOUNTING .....	11
4.3 CONNECTING THE CHARGING STATION .....	15
5 INTENDED USE.....	17
5.1 OPERATING MODES AND ELECTRIC VEHICLE CHARGING.....	17
5.2 CONNECTING THE VEHICLE .....	18
5.3 INDICATION OF SAFETY MEASURES.....	18
6 CHARGING STATION MAINTENANCE.....	19
7 TROUBLESHOOTING .....	19
8 STORAGE .....	21
9 TRANSPORTATION.....	21
10 DISPOSAL .....	21
11 ACCEPTANCE CERTIFICATE.....	21
12 MANUFACTURER'S WARRANTY .....	22

## SAFETY PRECAUTIONS

This Operating Instruction contains the necessary sections for technical data, technical maintenance rules, as well as safety instructions and recommendations for operating the Charging Station.

Before starting the work, you should carefully study all the rules and recommendations in the Instruction and follow them during operation. This will ensure the reliable operation of the product and the safety of its use.

When working with the Charging Station (ChS), the safety recommendations in this Manual, as well as the applicable local safety regulations and general safety regulations, should be observed.

Before starting any work on the Charging Station, make sure that the Instruction, in particular the Safety section and the corresponding safety regulations, have been fully read by your personnel and fully understood.

Important safety instructions in this Manual are indicated by symbols. These safety instructions must be strictly followed. You should always pay attention to them and follow the safety requirements in order to avoid accidents, personal injury, or property damage.



### WARNING!

Risk of injury or death.

This symbol indicates instructions that must be followed to avoid injury, trauma, or death.



### ATTENTION!

Risk of property damage.

This symbol indicates instructions which, if not followed, may result in property damage, functional failure, and/or damage to the Station or the vehicle connected to it.

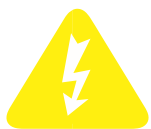

### WARNING!

Electric shock hazard.

This symbol warns of potentially hazardous situations involving electrical current. Failure to follow safety instructions increases the risk of serious injury or death. Care should be taken, especially during maintenance and repair.



### ATTENTION!

This symbol indicates tips and information that should be followed to ensure an efficient and trouble-free operation of the Station.

---

Strict adherence to the safety precautions outlined in these Operating Instructions and extreme care when using the equipment are essential to prevent and to reduce the likelihood of injury or damage to the equipment.

The Manufacturer shall not be responsible for any direct or indirect damages resulting from the use or the work with the electrical circuits of the equipment or the software described in this Manual.

The Manufacturer shall not be responsible for damage and/or malfunction caused by non-compliance with the requirements of the Manual.

The Manufacturer shall not be responsible for any personal injury or property damage, whether indirect or specific in nature, consequential damages, loss of business profit, interruption in work or loss of business information as a result of using the equipment described in the Manual.

Due to continuous improvement, the Developer shall reserve the right to make changes to the design of the equipment described in the Manual without prior notice.

## 1 GENERAL INFORMATION

### 1.1 APPLICATION

**SINGLE** – is a high-quality Charging Station designed and manufactured using effective solutions in the field of power electronics and technology based on a modern element base, using microcontroller signal processing technology, which ensures its high efficiency, functionality, and reliability. The solutions together with software and available interfaces, provides a flexible and productive charging solution for electric vehicles.

The product is equipped with an intelligent microcontroller operating system and communication devices that provide information exchange with an electric vehicle and set the amount of current and charging voltage, in accordance with the needs of the e-vehicle in real time.

The product has been designed for the simultaneous connection of up to two vehicles.

### 1.2 CHARGING STATION FUNCTIONALITIES





Mounting type	Wall / Floor
Online monitoring of device operation	Yes
Ability to adjust the charge current	Yes
Possibility of setting the rate at the Charging Station	Yes
Single case execution	Yes
Дисплей	Yes
Indication of the consumed electricity amount	Yes
User-defined interface management	Menu functions are controlled via the app
Bottom power cable entry	Yes
Case material	Steel with anti-corrosion coating

### 1.3 TECHNICAL CHARACTERISTICS

Charging mode, according to IEC 61851-1	Mode 3
Rated input voltage	1 / 3 phase(s), 230 V / 400 V
Maximum permissible input voltage deviation, no more than	± 10 %
Rated power supply frequency	50 / 60 Hz
Maximum permissible deviation of the mains frequency	± 0,2 Hz
Electric power consumed from the network, maximum	18.4kV·A

Display	• LED- display (20×2 characters)
Operational capabilities of the Station	RFID card (IEC 14443-1); Mobile app; Chip tag (optional)
Mechanical protection class, according to IEC 62262	IK10
Enclosure rating, according to IEC 60529	IP65
Ambient temperature	- 50 °C ... + 50 °C
Relative humidity	no more than 95% without moisture condensation
Weight, kg	10
Overall dimensions (H×W×D), mm	365×555×132
Communication (standards and protocols)	
2G	GSM GPRS Class 12, Quad-band: 850 / 900 / 1800 / 1900MHz
3G/4G (LTE)	LTE Cat 1, LTE-FDD: B1/B3/B7/B8/B20/B28A; GSM: B3/B8
RFID	ISO 14443 (A) (Mifare)
Ethernet	IEEE 802.3
Wi-Fi	802.11 a/b/g/n
OCPP	OCPP 1.6

## 1.4 CHARACTERISTICS OF THE STATION CONNECTORS

Charging station port	Type 1 (SAE-J1772)		
			
	Maximum output power	9,2 kW	18,4 kW
	Maximum charge current	40 A	80 A
	Maximum charge voltage	230 V	
Cable length	6,5 m		
Charging station port	Type 2 (Mennekes)		
			
	Maximum output power	22 kW	43 kW
	Maximum charge current	3×32 A	3×63 A
	Maximum charge voltage	400 V	
Cable length	6,5 m		
Charging station port	Soket Type 2		
			
	Maximum output power	22 kW	
	Maximum charge current	3×32 A	
	Maximum charge voltage	400 V	
Charging station port	GB/T AC		
			
Maximum output power	22 kW	43 kW	



Maximum charge current	3×32 A	3×63 A
Maximum charge voltage	400 V	
Cable length	6,5 m	

## 1.5 CHARGING STATION MODIFICATIONS

Charging Station modifications can be with any one connector or socket. Moreover, the Charging Station can be produced for commercial or individual use.

In the case of its commercial use, the Charging Station is equipped with a modem and to use it, you need to insert a SIM card.

In the case of its individual use, instead of the information display, an indicator panel, which displays the maximum possible charge current produced by the Station, is used. In order to change it, it is necessary to rotate the regulator at the ChS bottom.

## 1.6 APPEARANCE AND DIMENSIONS OF THE CHARGING STATION

The appearance of the station depends on the type of installation of the station - on a wall or on a pedestal. The appearance and dimensions of the station are shown in Figure 1.

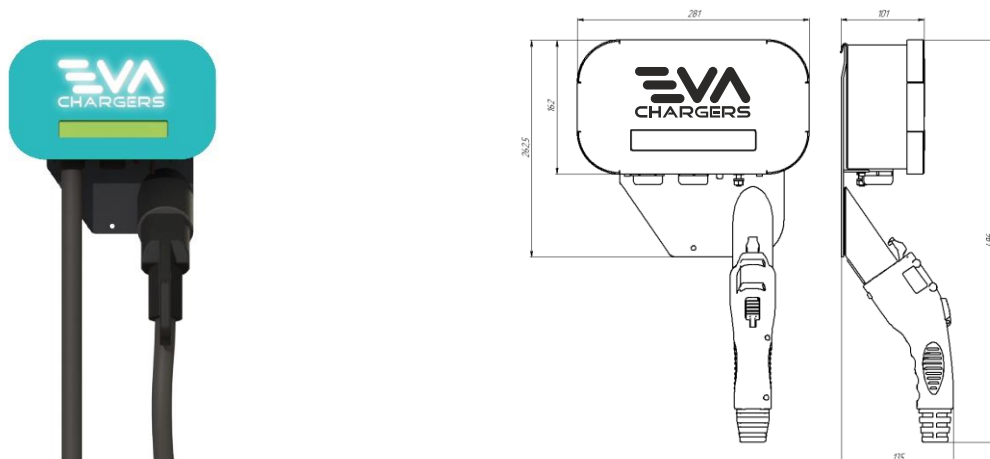

Figure 1a – Appearance and dimensions of the Station for wall mounting

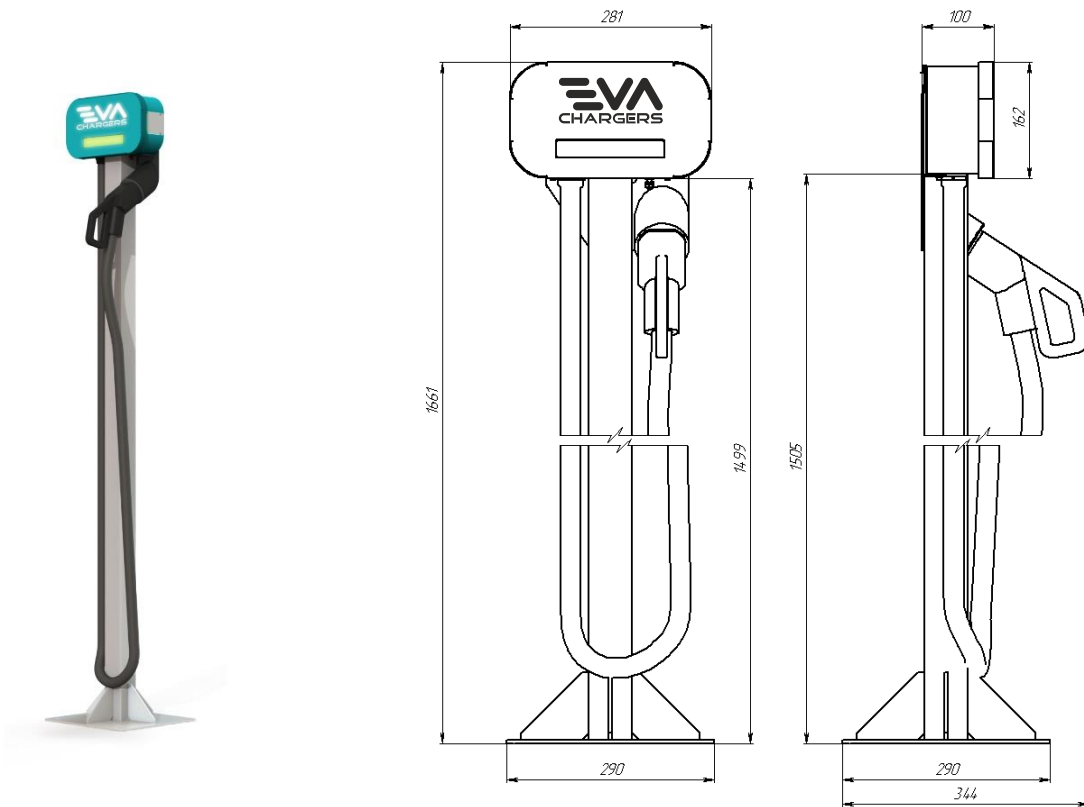

Figure 1b – Appearance and dimensions of the Station for floor mounting

## 2 COMPLETESSET

### Wall mounting

Single Charging Station	1
Operating Manual	1
Mounting bracket	1

### Floor mounting

Single Charging Station with pedestal	1
Operating Manual	1

## 3 LABELLING AND MARKING

The labeling and marking of the Charging Station is made on the nameplate located on the side panel of the Station case.

## 4 SETTING-UP PROCEDURES

### 4.1 OPERATING RESTRICTIONS



The Charging Station is designed exclusively for charging electric vehicles. Please charge only compatible e-vehicles.

Failure to comply with the requirements for operation, technical maintenance, and repair described in this Manual excludes any liability of the Manufacturer in the case of malfunctions in the Station operation.

According to IEC 60947-1, the installation altitude of the Charging Station above sea level should not exceed 2,000m.

Please follow the safety instructions to avoid injury and material damage when working with the Station.

During the installation and operation of the Charging Station, the following should be observed: the Rules for the Design of Electrical Installations, the Rules for the Technical Operation of Electrical Installations of Consumers, the Safety Rules for the Operation of Electrical Installations of Consumers in terms of electrical installations up to 1,000V, according to GOST 22261.

By the method of protecting a person from electric shock, the Charging Station corresponds to Class 1, in accordance with GOST 12.2.007.0.

### 4.2 CHARGING STATION MOUNTING

Please make sure the installation site has adequate GSM or 4G (LTE) cellular coverage. Cellular repeaters may be required to ensure good signal strength in underground garages or other enclosed parking lots.

It is recommended to locate the Station under a canopy to protect it from direct exposure to precipitation and sunlight.

For wall-mounted Charging Stations, a place should be prepared for attaching the bracket. When choosing the location of the Station, please keep in mind that there must be a distance of at least 0.5 meters to the left and right of the Station building to any obstacle. The holes for the anchor screws should be positioned as shown in Figure 2.

For pedestal Charging Stations, the site should be prepared in advance by following the instructions below.

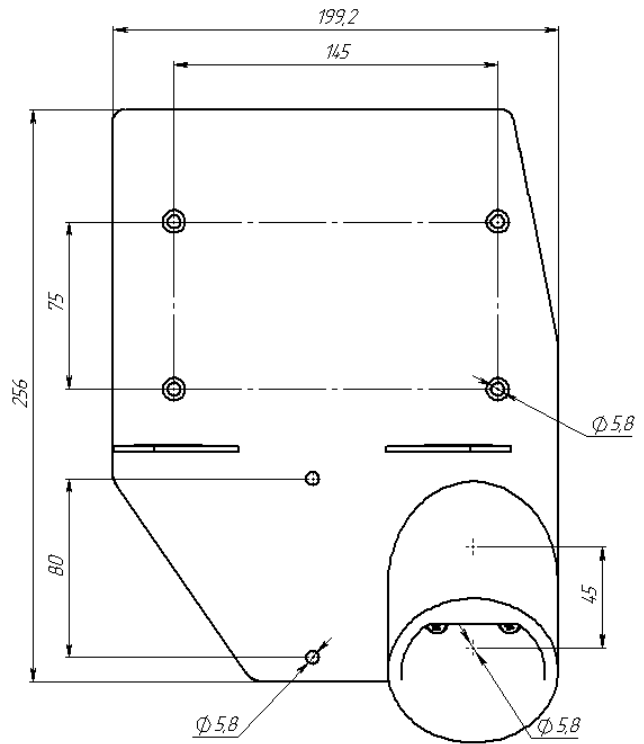

Figure 2 – Mounting plate

When choosing a location for the Charging Station, the following conditions should be met: there must be a distance of at least 1 meter between the case of the Charging Station and a wall or any obstacle. Adequate space for servicing should be provided in front and behind the ChS.

The Station shall be installed on a foundation (a prepared concrete foundation) measuring 900×900×300mm. Underground utilities should not be laid in the foundation area.

The foundation shall be poured into a well-rammed base with a pre-laid cable duct and a placed metal insert. For the foundation, it is necessary to use a mixture of crushed stone with cement at least M400. The surface of the foundation should be carefully leveled to avoid distortion of the Station during mounting.

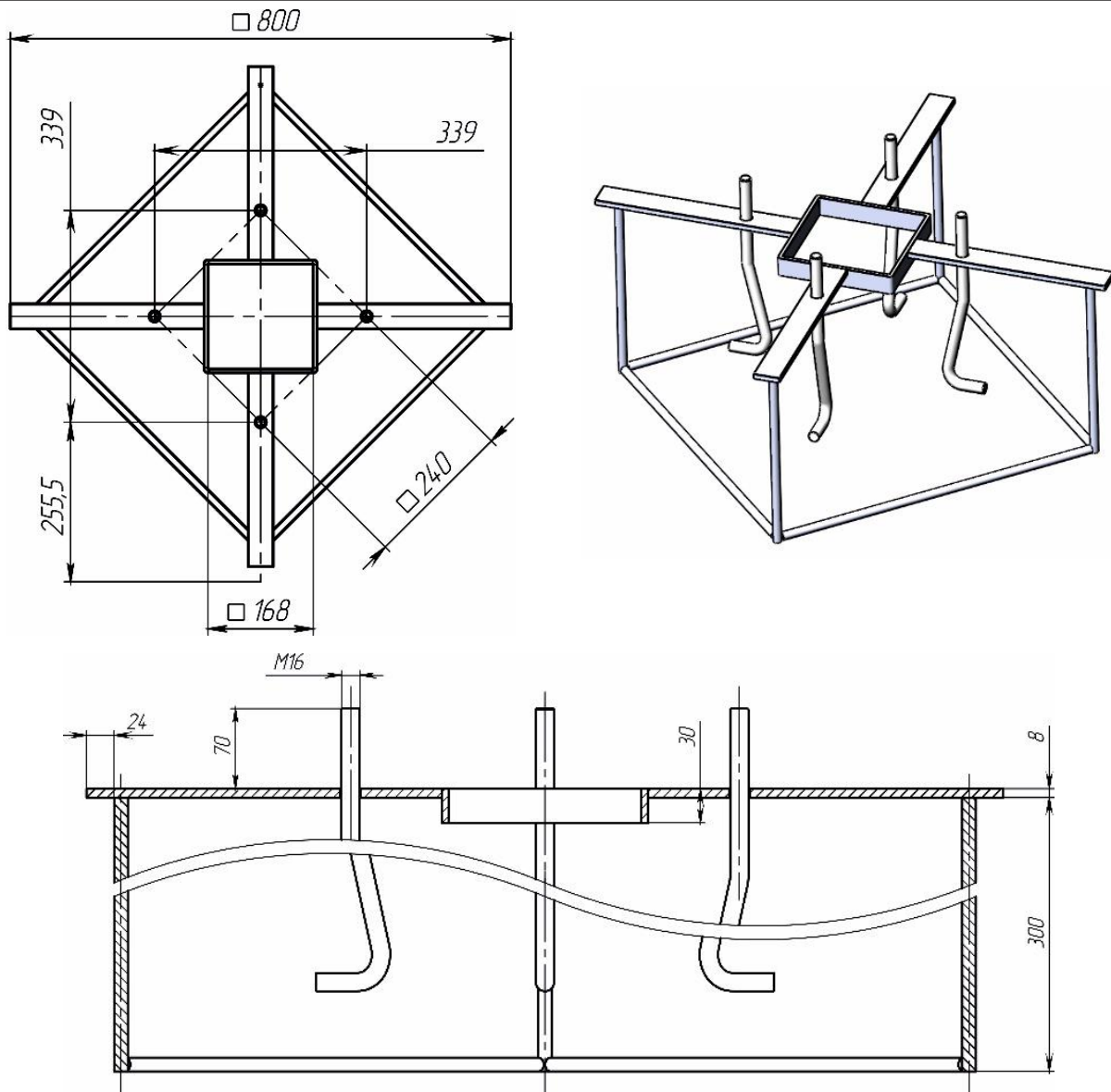

Figure 3 – Appearance and dimensions of the insert

The dimensions of the pedestal

foundation of the Charging Station are shown in Figure 4, the thickness of the plate is 5mm.

Along with the preparation of the foundation, it is necessary to ensure the laying of the power electrical cable (not included in the delivery set). The required cable length above the foundation is at least 2 meters.

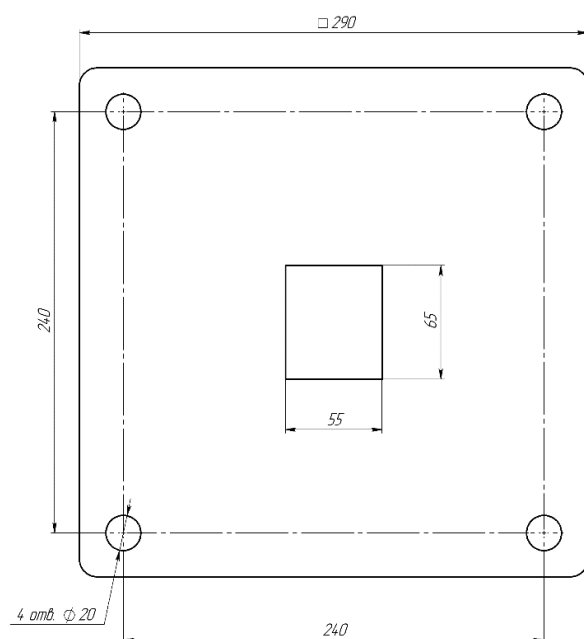

Figure 4 - The pedestal foundation (bottom view)

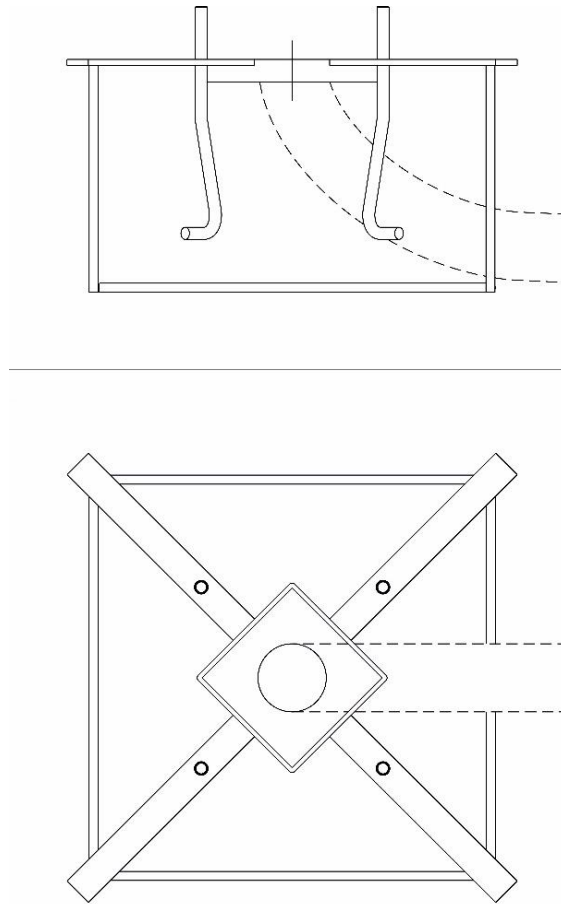

Figure 5 - The station foundation



**WARNING!**

Only qualified personnel should connect the power cable to the AC mains.

It is recommended to select the cross-section of the power cable based on the ChS power.

Table 1 - Recommended cross-section of power cable

Charging Station power, kW	Power cable cross-section, mm <sup>2</sup>
16	5×2,5
32	5×6
40	5×10
80	5×35

When laying the power cable, an AC circuit breaker should be installed between the Station and the mains.

Depending on the Charging Station power and the number of connected phases, it is recommended to use a 2-pole (for single-phase connection), 4-pole (for three-phase connection) circuit breaker in the range from 16A to 80A.

### 4.3 CONNECTING THE CHARGING STATION

After the Station has been transported, before installing it, please make sure that all internal elements are properly fixed and there is no mechanical damage.

The Charging Station does not require any special settings and adjustments before being put into operation.

Before connecting the Charging Station, please make sure that:

- The mains supply cable is de-energized by external disconnecting devices.
- The mains power input has a connection diagram: 3 phases with separate neutral (N) and ground (PE) conductors.
- When connecting with a 4-wire cable, please carry out the protective grounding with a separate wire.

Depending on the configuration of the Charging Station, the connection to the external power supply network can be carried out in several ways:

- To an F-type socket (when using J1772 connector with 16A current limitation);
- To socket CEE type 32A 400V;
- To the terminal block as shown in Figure 6 (for the case using a 3-phase connection or only L1 for a single-phase connection).

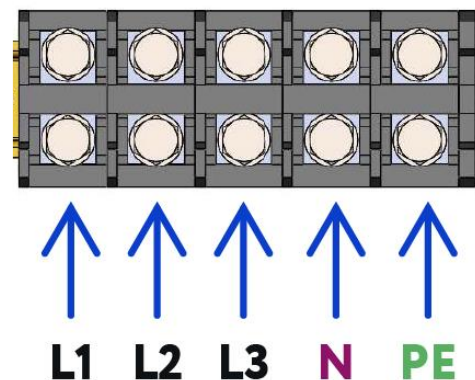

Figure 6 - Input busbars

#### ATTENTION!

**THE FIRST CONNECTION THAT SHOULD BE PERFORMED IS THE GROUND WIRE TO THE GROUND BUS LABELED "PE"**



**IT IS FORBIDDEN TO TURN ON THE CHARGING STATION WITHOUT A CONNECTED GROUNDING!**

Failure to comply with this requirement may lead to voltage supply to the Charging Station case, electric shock to service personnel and consumers, as well as to the Charging Station failure.

### ATTENTION!

When connecting the Charging Station to the mains, it is necessary to use a separate circuit breaker, the power and number of phases of which is calculated depending on the configuration of the Charging Station.

For the Charging Station with a J1772 connector and a capacity of 9.2kW, it is recommended to use a single-phase circuit breaker with a breaking current of 50A.

For the Charging Station with a Type 2 connector (Menkes) with a capacity of 22kW, it is recommended to use a three-phase circuit breaker with a breaking current of 40A.

Further, with the external switching devices, it is necessary to connect the power cable to the AC network and then to turn the three-pole circuit breakers into the operating position.



### ATTENTION!

Before turning on the station, contact technical support to activate the SIM-card.

In order to turn on the Charging Station, it is necessary to:

- Install the SIM card (if a modem is installed in the Charging Station)) of the mobile network operator (if an external SIM card is used). To do this, please follow these steps:
  - remove the ChS cover by unscrewing two screws on the back of the Station;
  - remove the modem cover;
  - install a SIM card;
  - close the modem cover;
  - put on the ChS cover by screwing in two screws on the back of the Station;
- Move the circuit breaker on the switchboard to the operating position (up).



## 5 INTENDED USE

### 5.1 OPERATING MODES AND ELECTRIC VEHICLE CHARGING

Information about the ChS operating modes (the state of the connectors and the charging parameters) is shown on the display. The display also shows data on software versions, a modem number, the Station number in «EVA CHARGERS» billing, a mobile network status, etc.

The information shown on the display depends on the software version and may differ from version to version.

#### Autoenterprise

**V:2.02.1642**  
**M006335**

After the supply voltage is applied, the Station display shows information about the software version and the modem serial number.

In the event of a malfunction of the Charging Station, you should inform the serial number of the modem to the service center for diagnostics and restoration of its work.

#### #1 : Ready

**Connect plug**

In standby mode, the display shows information about the status of the connectors.

#### #1 : Charging

**0:00:50**                      **42.2A /**  
**366V**

In the e-vehicle charging mode, the LCD displays information about charging time, voltage level, and current value.

## 5.2 CONNECTING THE VEHICLE



Figure 7. Connectors available for configuration



Figure 8. Connectors available for configuration

## 5.3 INDICATION OF SAFETY MEASURES

The Charging Station operating system is powered from the mains through an additional circuit breaker.

The output cable is connected via grommets/cable glands.

## 6 CHARGING STATION MAINTENANCE

### ATTENTION!

All maintenance work should be carried out by the Manufacturer's representative or a qualified technician. Do not attempt to carry out maintenance work yourself, as this may result in electric shock and/or loss of functionality of the Charging Station.



Improper maintenance can result in a serious injury or an equipment damage. For this reason, this work can only be performed by authorized, trained personnel who are familiar with the principles of the Station operation and strictly adhere to all safety instructions.

The use of explosive or flammable cleaning agents creates a fire or explosion hazard.

Do not store flammable or explosive liquids near the Charging Station.

### ATTENTION!



Please ensure that the Charging Station is de-energized before carrying out any maintenance work.

During operation, the following routine maintenance shall be performed:

- Visual inspection for the equipment overheating; check, tightening of connections;
- Identification of defective parts, assemblies, their repair and replacement.

Before starting any maintenance or cleaning work on the Charging Station or working on any circuits connected to the Charging Station, the authorized service personnel should disconnect all AC sources from the Charging Station to reduce the risk of electric shock.

It is strictly forbidden to modify or alter the design of the Charging Station in any way without the written consent of the Manufacturer!

All signs, labels, and pictograms placed on the Charging Station must be visible and readable. Signs, labels, or pictograms that have been damaged or illegible must be replaced immediately. Please contact the Manufacturer to agree on such issues.

## 7 TROUBLESHOOTING

Malfunction, external manifestations, and additional signs	Possible reason	Troubleshooting method
	Modem failure / SIM card inoperative	Replacing the GSM modem or checking the status of the SIM card

Malfunction, external manifestations, and additional signs	Possible reason	Troubleshooting method
Loss of connection with the server	Poor signal strength of the mobile network / The antenna of the GSM modem failed / The Station location outside the coverage area of the mobile network	Replacing the antenna with a more powerful one
Damage to the charging cable or connector	Physical deterioration, careless handling of equipment	De-energize the device. Contact technical support for cable replacement
The Charging Station display does not work (there is no information on the Station display)	No input voltage	Find out the reason for the lack of input voltage and restore the power supply
	Circuit breakers tripped	Bring the circuit breakers to the operating position
	Display is defective	Contact the Technical Support Service
Other malfunctions	Malfunctions caused by external and internal factors	Contact the Technical Support Service

### TECHNICAL SUPPORT

You can contact the Technical Support Service in any way convenient for you indicated on the website

[evachargers.com](http://evachargers.com)

In order to quickly resolve the problem, it is necessary to report the Station modem number or the Station number in the «EVA CHARGERS» billing.

## 8 STORAGE

The Charging Station should be stored in its original package until it is installed at the place of permanent use.

### STORAGE CONDITIONS:

- The Charging Station should be stored in dry, heated rooms, free of dust, corrosive materials, vapors, and combustible materials.
- Store Charging Station in a warehouse with adequate weather protection.
- During storage, the Charging Station should be protected from shocks.
- Storage temperature: 0°C to +40°C (32°F to 104°F).
- Relative humidity should be no more than 85%

## 9 TRANSPORTATION

The Charging Stations should be transported in transport package by rail, by truck, and by air without limiting the distance of transportation, taking into account the rules for the carriage of goods applicable to these modes of transport.

When transporting, the center of gravity of the Charging Station should be taken into account in order to minimize the risk of tipping over.

During transportation, the Charging Stations should be reliably protected from movement inside the vehicle. Straps and padded inserts should be used to secure the Station and steps should be taken to protect the Station from damage by other items being transported.

Transportation terms and conditions of the Charging Station are OZh4 (extra severe conditions), according to GOST 15150.

The weight of the Charging Station in the transport package does not exceed 100k.

## 10 DISPOSAL



### ATTENTION!

Do not dispose of the Charging Station with household waste!

The electronic components of the Charging Station should be disposed of in accordance with current legislation regarding the disposal of electronic and electrical waste.

If you have any further questions, please contact your supplier.

## 11 ACCEPTANCE CERTIFICATE

### CHARGING STATION

**SINGLE**

DEIGNATION

manufactured and accepted in accordance with the mandatory requirements

**EN 61851-1, EN 61851-23**

PRODUCT NAME

**XXXXXXXXXX**

PRODUCTION SERIAL NUMBER

and found fit for service

Chief of QCD

L.S.

SIGNATURE

FULL NAME

DATE

## 12 MANUFACTURER'S WARRANTY

The Manufacturer shall guarantee that the quality of the product shall meet the requirements of the Operating Manual.

Consumer requirements that comply with the law can be submitted during the warranty period.

The warranty period from the date of the product commissioning is 12 months, but not more than 18 months from the product delivery date to the consumer.

The service life of the equipment is 10 years.

Warranty for parts and components after their repair by replacing them during the warranty period is 12 months from the repair date, but not less than the warranty period for the equipment as a whole.

The warranty shall not apply to the equipment damaged as a result of:

- incorrect electrical, mechanical connection;
- use of the equipment for purposes other than those intended ones or in accordance with the Operating Instruction;
- external mechanical influences or violation of the rules of transportation and storage;
- non-compliance of electrical power with the standards and norms specified in the Operating Instruction;
- actions by third parties or force majeure;
- dismantling, maintenance, or repair carried out by a person who is not a representative of the manufacturing company;
- changes in the product design, not agreed with the Manufacturer.

The Manufacturer of the equipment shall not be responsible for possible costs associated with the installation and dismantling of the warranty equipment, as well as for damage caused to other equipment located at the consumer's as a result of malfunctions (or defects) that occurred during the warranty period.